

IN 2050 THE WORLD POPULATION WILL EXCEED 9 BILLION. 71% WILL LIVE IN URBAN AREAS

SUPPORTING THE NEEDS OF FOOD WILL REQUIRE 1.000.000.000 ACRES OF FARMLAND

LA CITTA' CONSUMA E NON PRODUCE LA CITTA' DEVE RECEPIRE IL CAMBIAMENTO

SCUOLA D'ARCHITETTURA E DESIGN ANNO ACCADEMICO 2012/13. TESTI DI LAUREA IN PROGETTAZIONE AMBIENTALE DELL'ARCHITETTURA. RELAZIONE PROF. ARCH. GIUSEPPE LUCIDI. COORDINATORE PROF. ARCH. EDOARDO BARBERA. LAUREANDI ANGELO FIOGLIOLA

La ricostruzione di Londra conferma un approccio pragmatico, un costume progettuale per soluzioni "caso per caso" che ne faranno "the linque City", una città sempre aperta, sempre in qualche modo "provvisoria", una città dalla crescita enorme, abnorme, mostruosa, dalla fisionomia eccentrica che unisce una smisurata grandezza (per estensione) a una vorticosità mobilità" Aldo Benedetti



CITY OF LONDON

TOWER OF LONDON

TOWER BRIDGE

LONDON_make it happen

SISTEMI URBANI, COMPONENTI E STRATIGRAFIE



L'IMPRONTA DELLA CITTA' - IL SISTEMA METROPOLITANO

DATI DEMOGRAFICI/LONDRA METROPOLI EUROPEA
 POPOLAZIONE RESIDENTE CORE 7.825.200 ab.
 SUPERFICIE CORE 1.572,1 KM2
 DENSITA' 4.977,55 ab/km2
 POPOLAZIONE RESIDENTE AREA METROPOLITANA 14.789.485 ab.
 SUPERFICIE AREA METROPOLITANA 2.584 km 2

INDICE DI VECCHIAIA AM 75,5
 STRANIERI RESIDENTI NEL CORE 33,6%

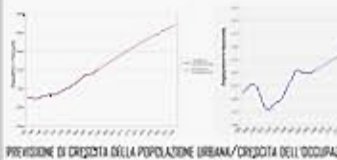

PREVISIONE DI CRESCITA DELLA POPOLAZIONE URBANA/CRESCITA DELL'OCCUPAZIONE



L'IMPRONTA DELL'UOMO - IL SISTEMA ARTIFICIALE



L'IMPRONTA DELLA NATURA - IL SISTEMA AGRICOLO E DEL VERDE

UTILIZZO DI SUOLO DATI
 TERRITORIO URBANO 22%
 352.373 ha
 TERRITORIO NATURALE 9%
 140.432 ha
 ACQUA 2%
 23.508 ha
 TERRITORIO AGRICOLO 67%
 1044.320 ha



IL SISTEMA DELLA MOBILITA'



TESSUTO URBANO - CONFRONTO CON ALTRE METROPOLI



"L'identità diventa un feroce fissa, inflessibile... Parigi può diventare solo più parigina... ma ci sono delle eccezioni come Londra - la sua sola identità è la mancanza di una identità ben definita... continua a diventare meno londinese, più aperta meno statica" Rem Koolhaas JUNKSPACE



AREA DI PROGETTO_achse

OSSERVANDO DALL'AREA DI PROGETTO...

CENTRALITA' URBANA E AREA DI OPPORTUNITA' - LONDON PLAN

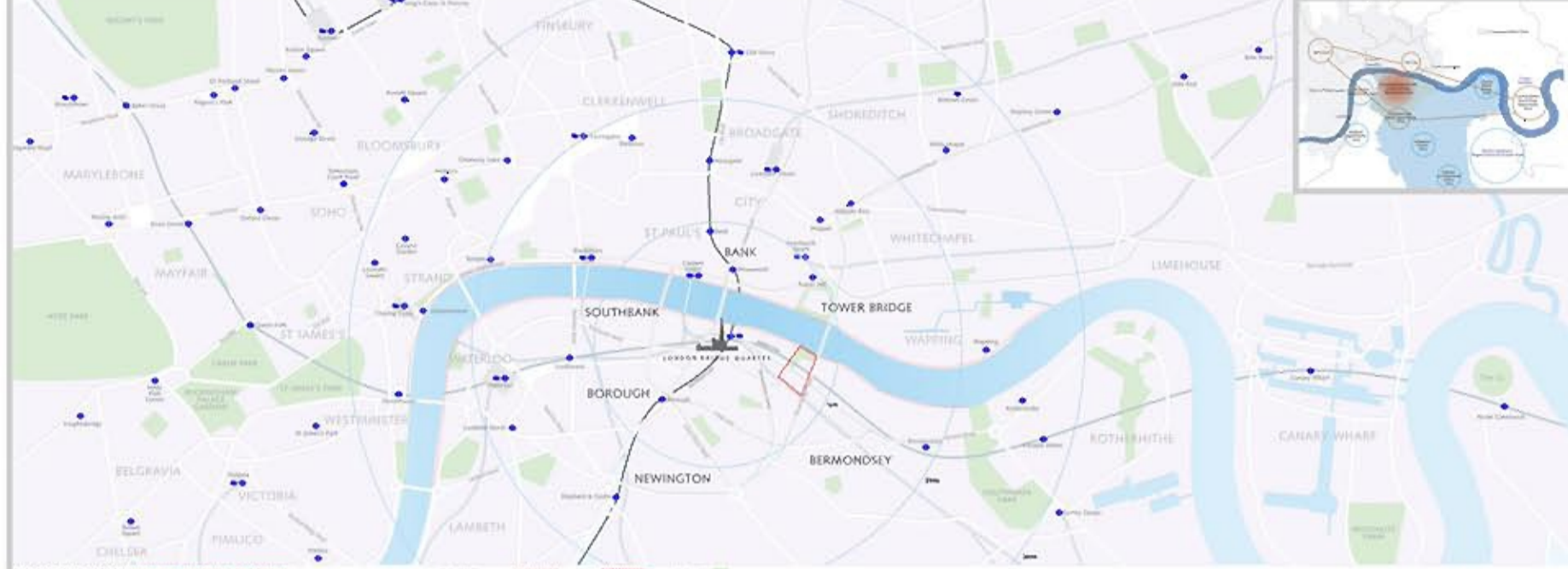

LONDON CITY REBORN/GREATER LONDON E I 32 BORGH

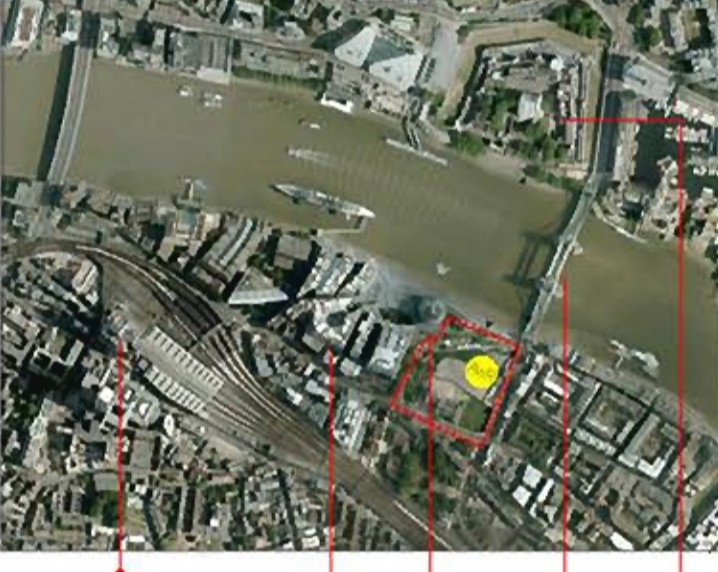
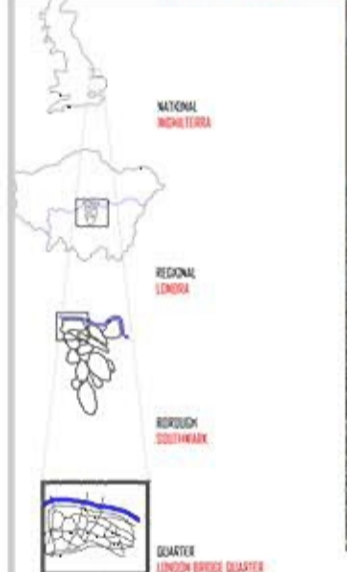

LONDON BRIDGE QUARTER - ANALISI DEL SISTEMA URBANO



- Occupies**
 - 1 Bacon & Woodrow
 - 2 Berwin Lighton Partner
 - 3 BlackRock
 - 4 CIBC
 - 5 Clarkson
 - 6 Ernst & Young
 - 7 Express Newspapers
 - 8 Financial Times
 - 9 Health & Safety Executive
 - 10 IPC Media
 - 11 Lawrence Graham
 - 12 LIFEE
 - 13 Man Group
 - 14 Marsh
 - 15 Norton Rose
 - 16 Ofcom
 - 17 Petro-Canada
 - 18 Prudential M & G
 - 19 PWC
 - 20 Rabobank
 - 21 Royal Bank of Canada
 - 22 Royal Bank of Scotland
 - 23 St Berwin
 - 24 Tate & Lyle
- Restaurants & Bars**
 - 1 Butler's Wharf Chop House
 - 2 Champor Champor
 - 3 Qelina Studio Cafe
 - 4 The Garrison
 - 5 The George Inn
 - 6 Magdalen
 - 7 Le Pont de la Tour
 - 8 Royal
 - 9 The Southwark Rose
 - 10 The George Inn
 - 11 Tas
 - 12 Vinopolis
- Culture**
 - 1 Borough Market
 - 2 Design Museum
 - 3 Fashion & Textile Museum
 - 4 Globe Theatre
 - 5 The Golden Hinde
 - 6 Jerwood Space
 - 7 Rose Theatre
 - 8 St Paul's Cathedral
 - 9 Southwark Cathedral
 - 10 Tate Modern
 - 11 Unicorn Theatre



AREA DI PROGETTO...

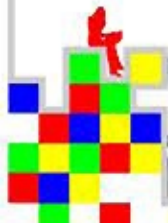

LOFT
 london farm tower

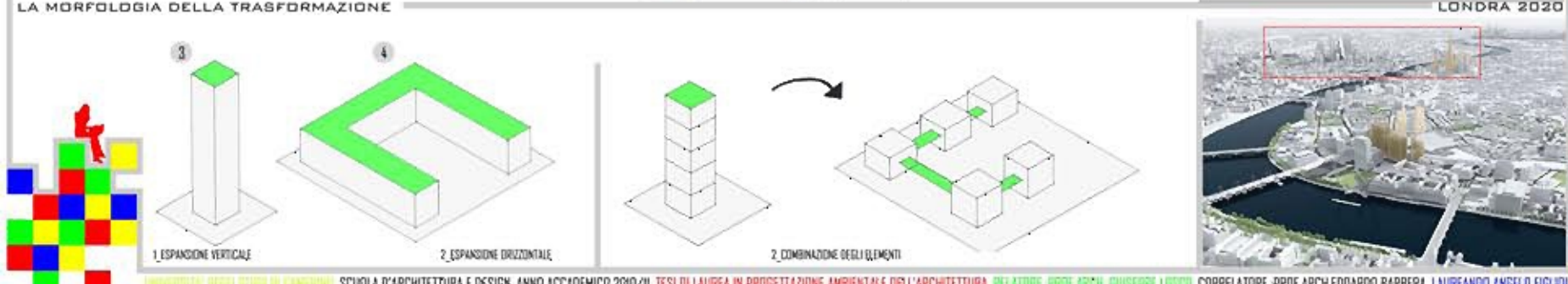
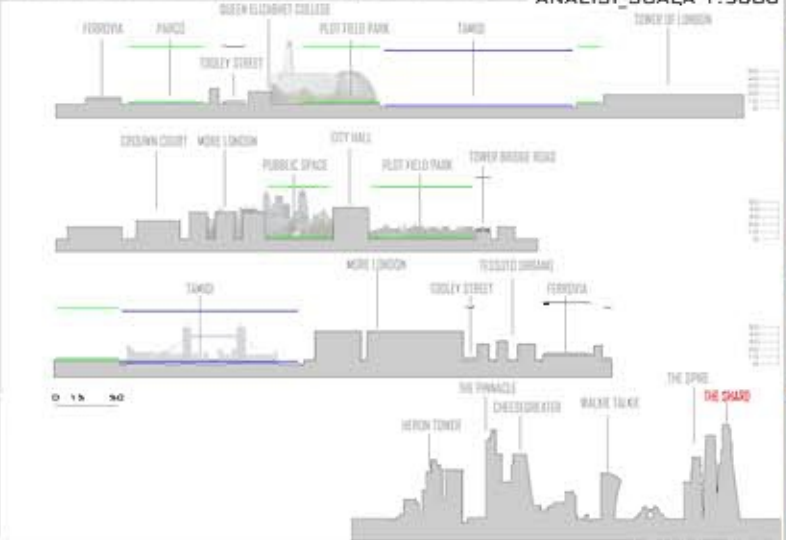
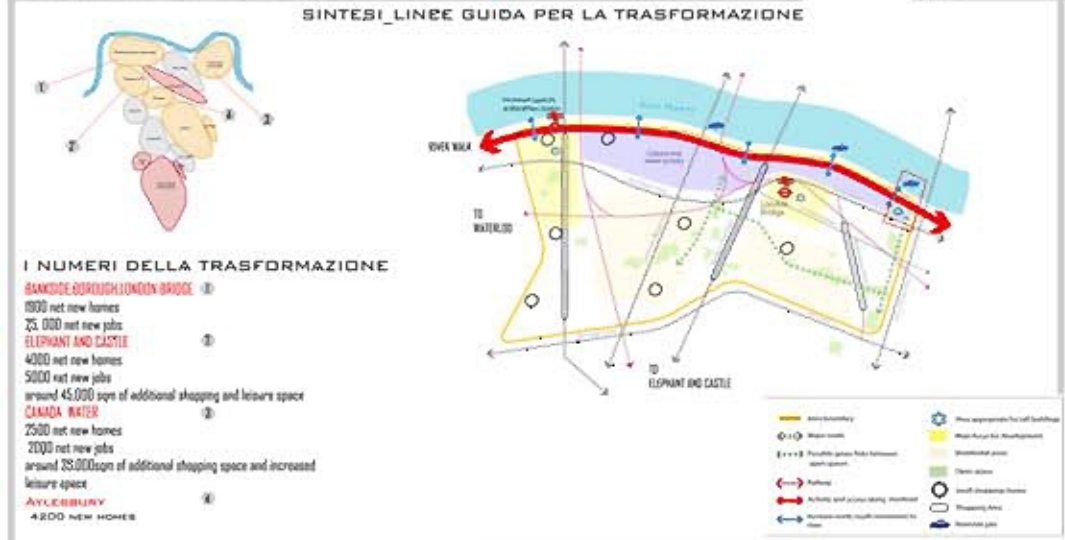
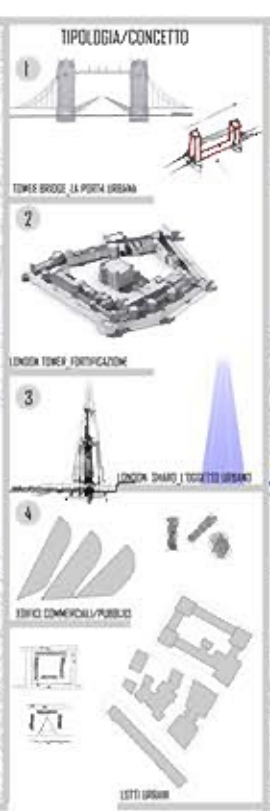
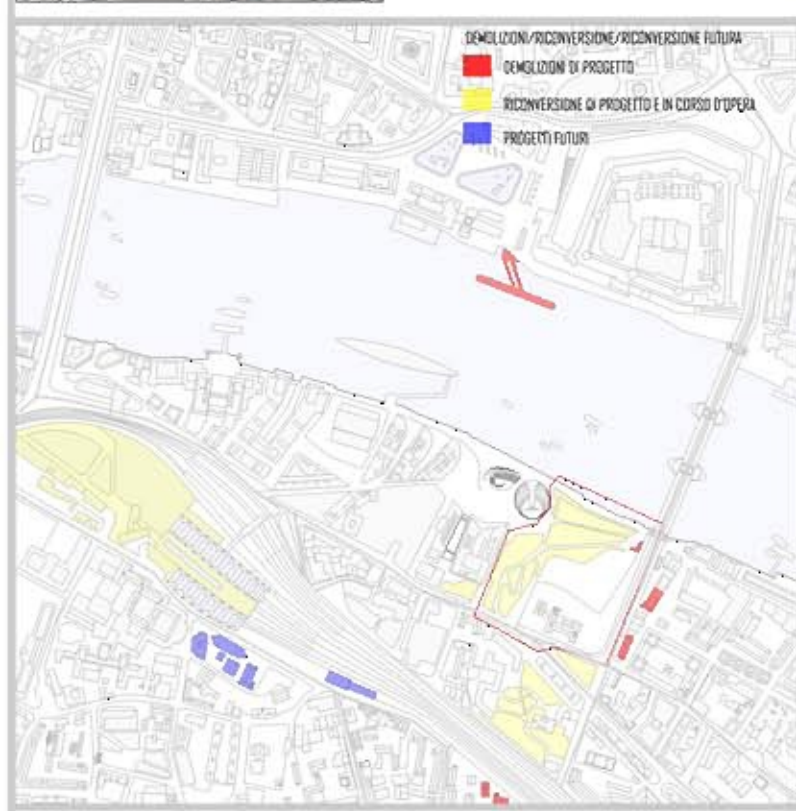
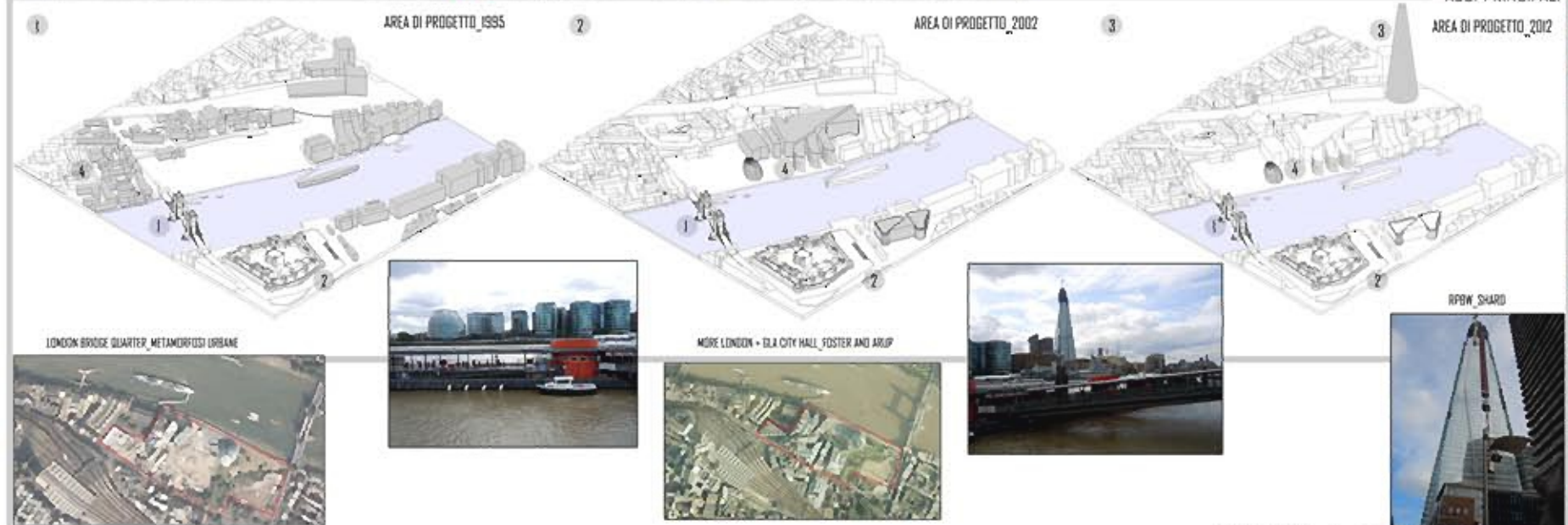
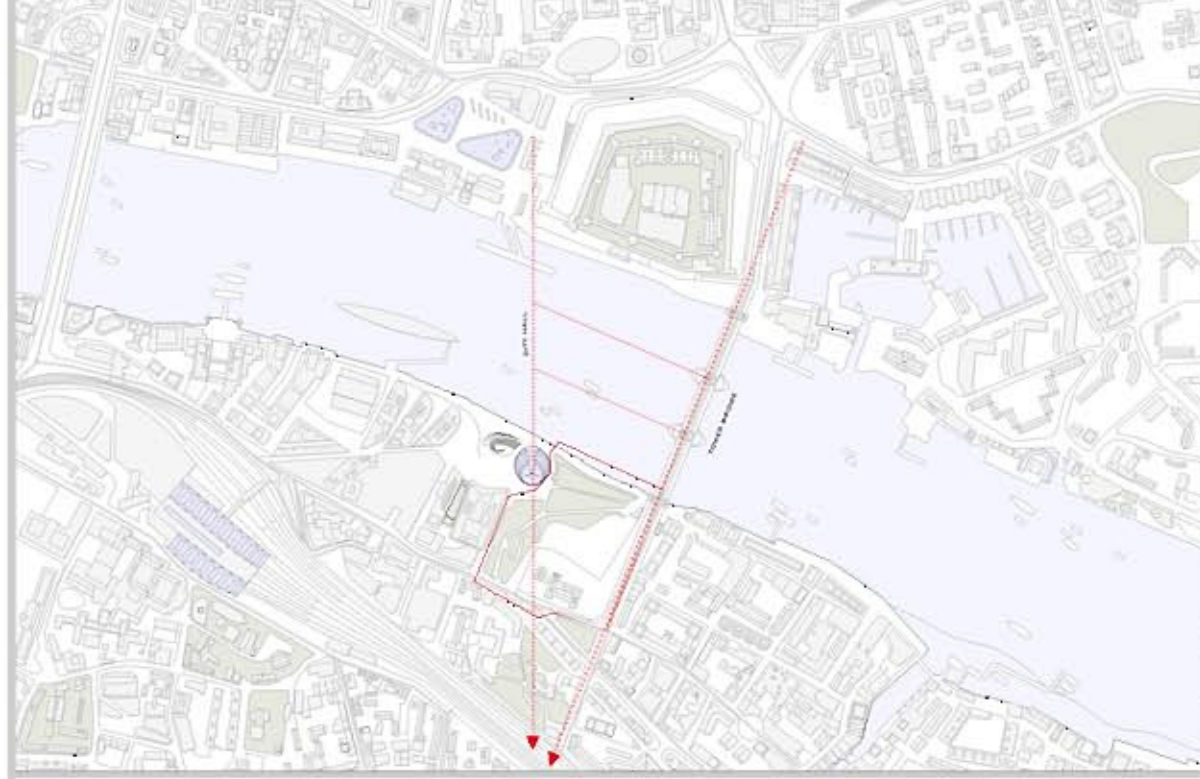

Londra appare una costruzione fatta tanta di solida pietra quanto di processi immaginativi. La sua stessa incessante metamorfosi causata dagli eventi storici, dalle pestilenze e dagli incendi, diviene argomento di narrazioni che ne esplorano i paesaggi da un'epoca all'altra come se essa fosse una creatura vivente irrequieta, caparriosa. Carlo Pagelli

BUILD	SEED	HARVEST	EAT

CONCORSO LOFT LONDON 2011
 Farm 40%
 mixed residential 40%
 commercial 15%
 services 5%



RE/VITALISE[®]
 work in progress

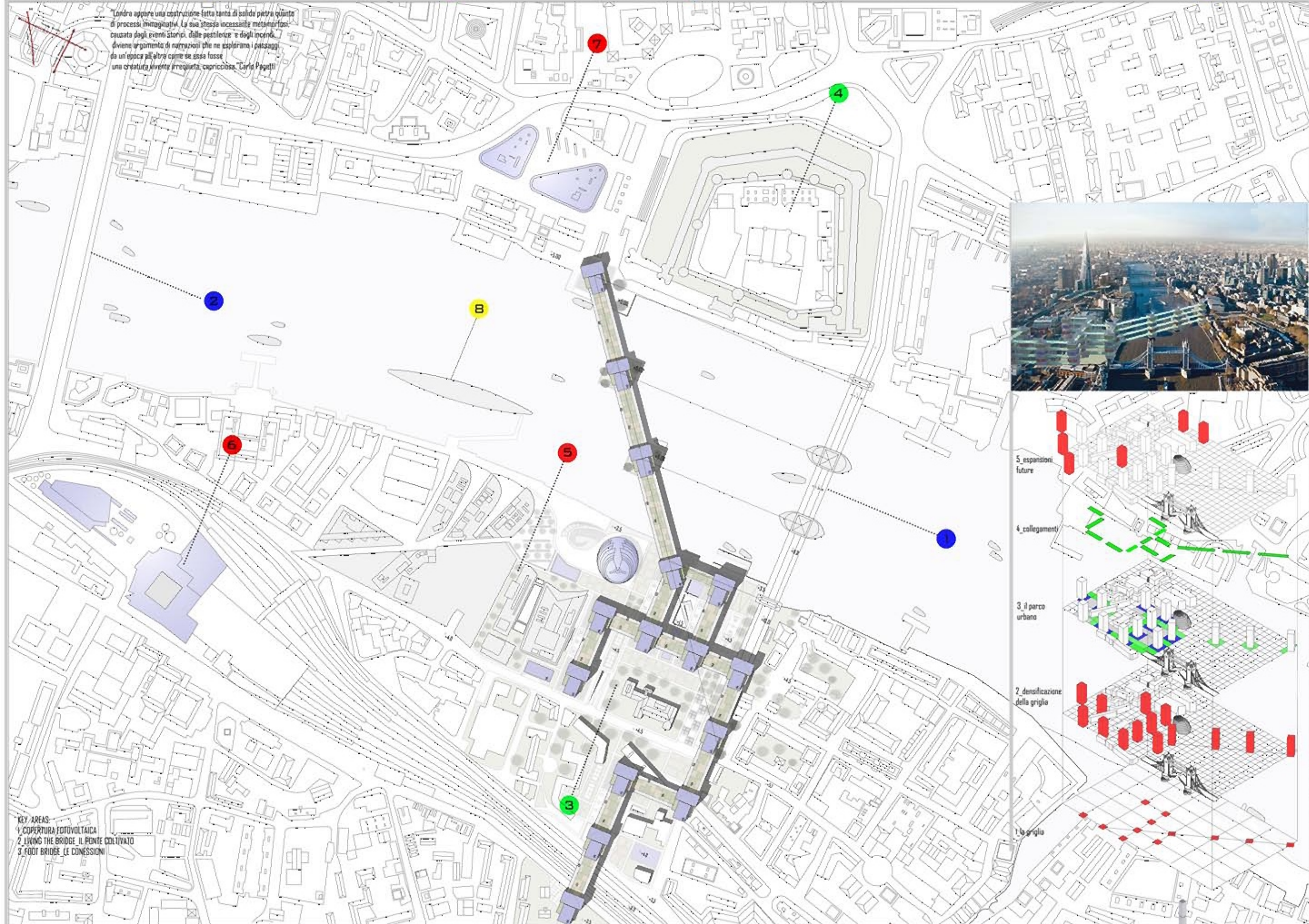

KEY AREAS:
 1 COPERTURA FOTOVOLTAICA
 2 LIVING THE BRIDGE IL PONTE COLTIVATO
 3 FOOT BRIDGE LE CONNESSIONI

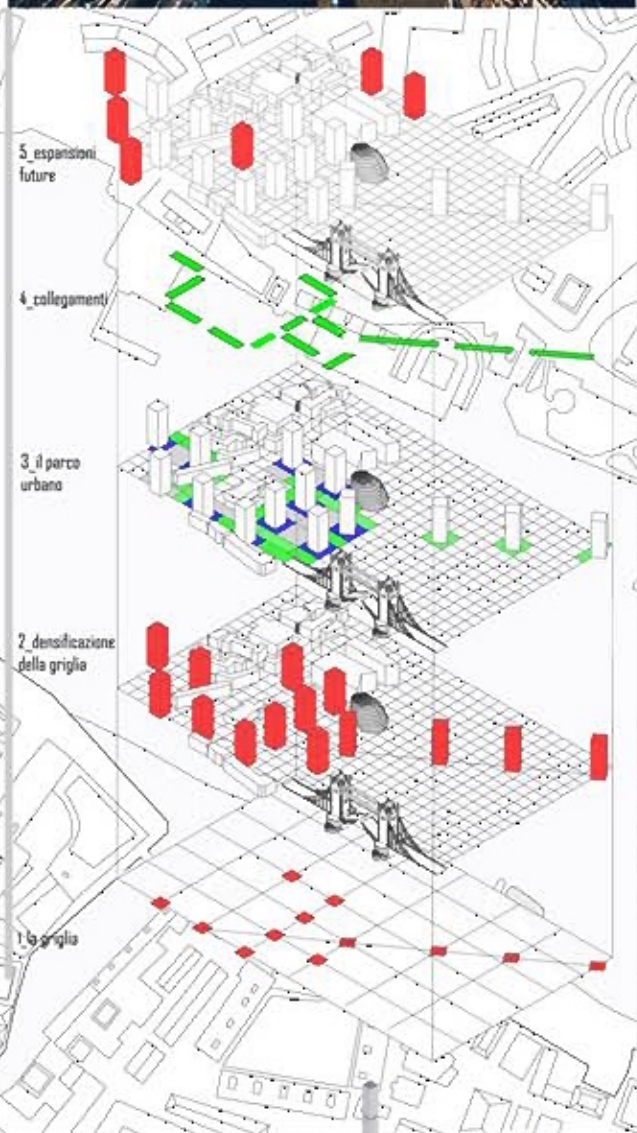

LOFT
 london farm tower

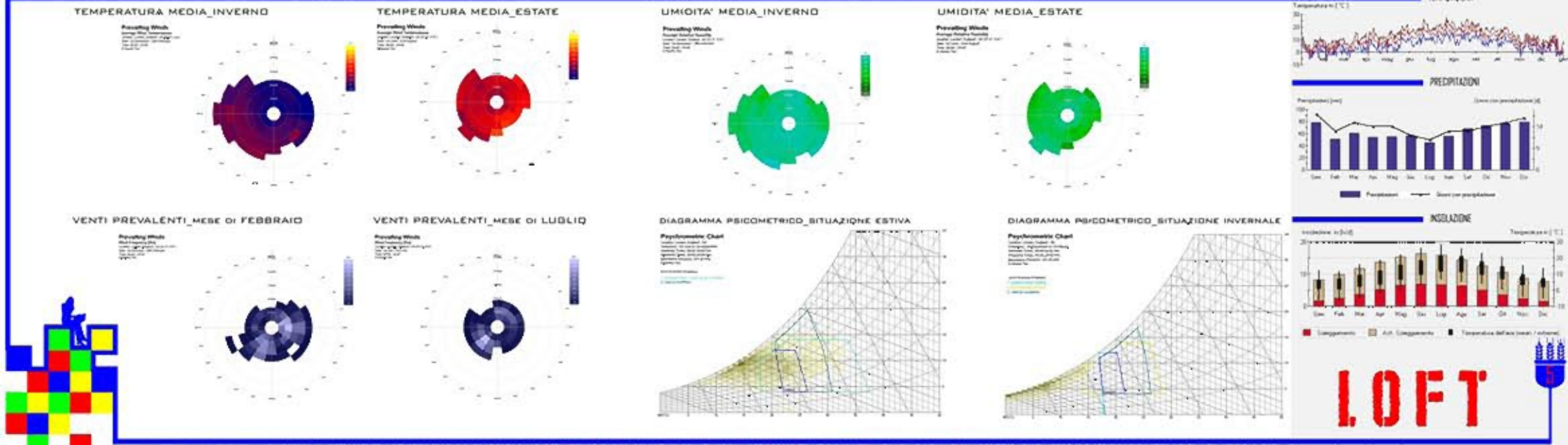
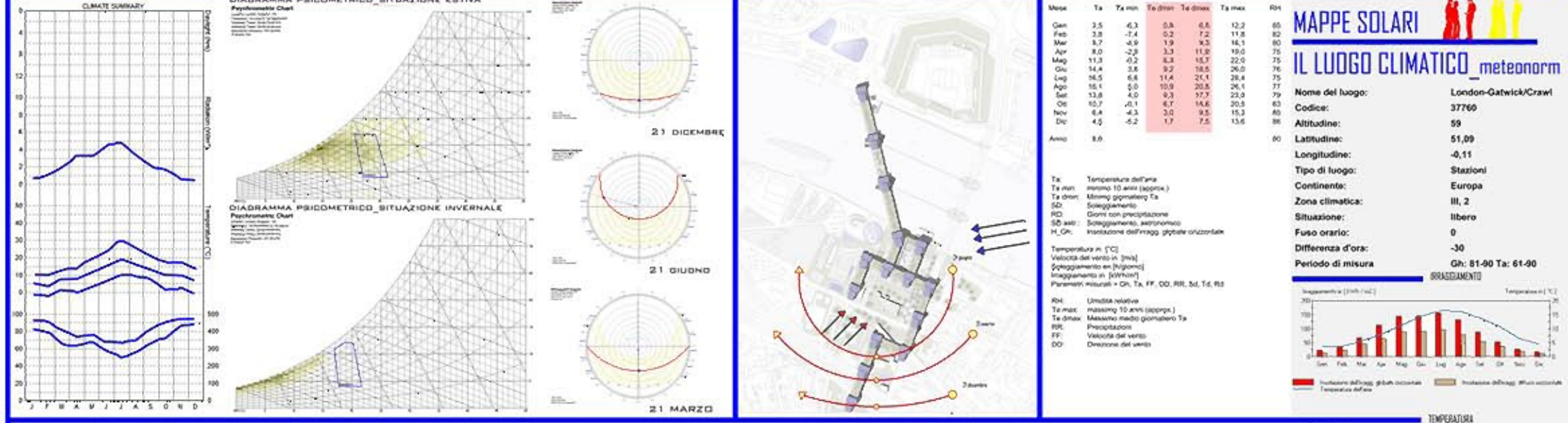
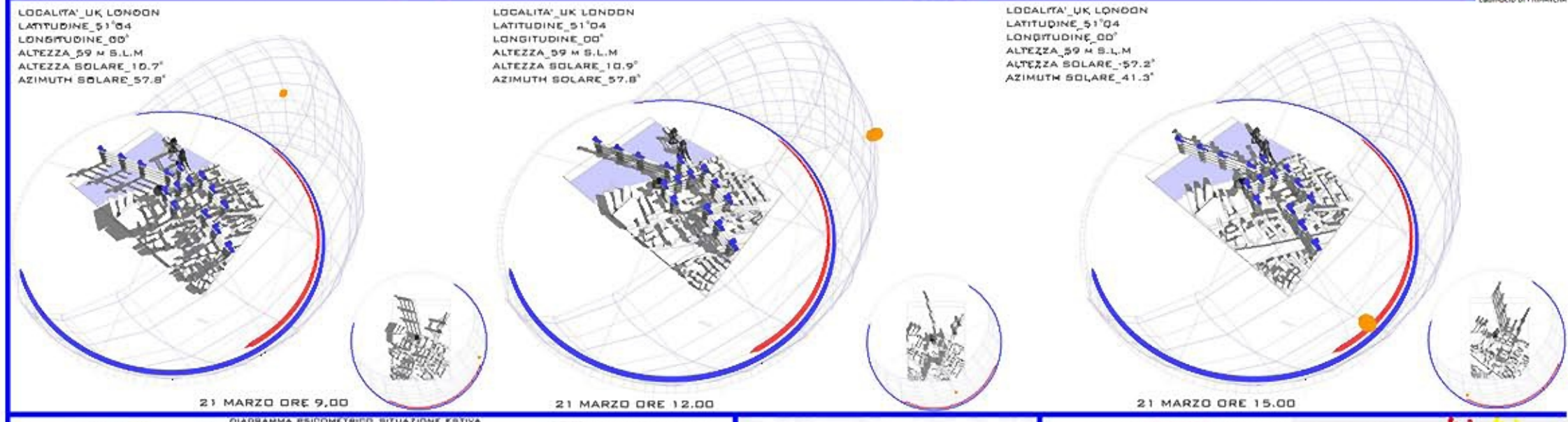
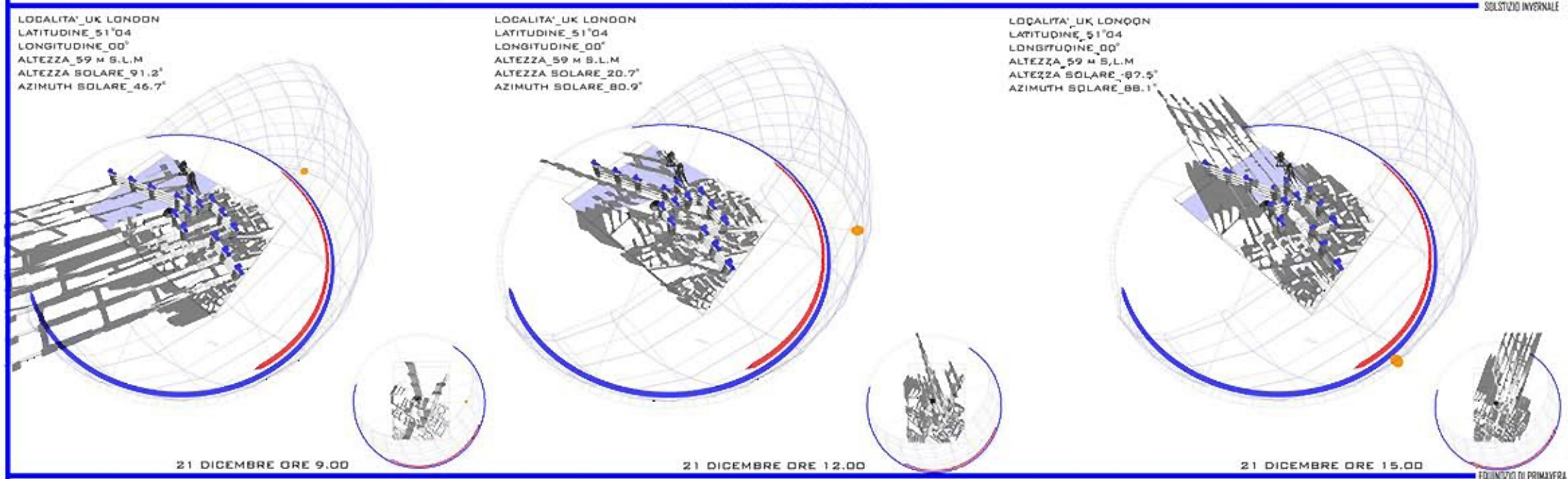
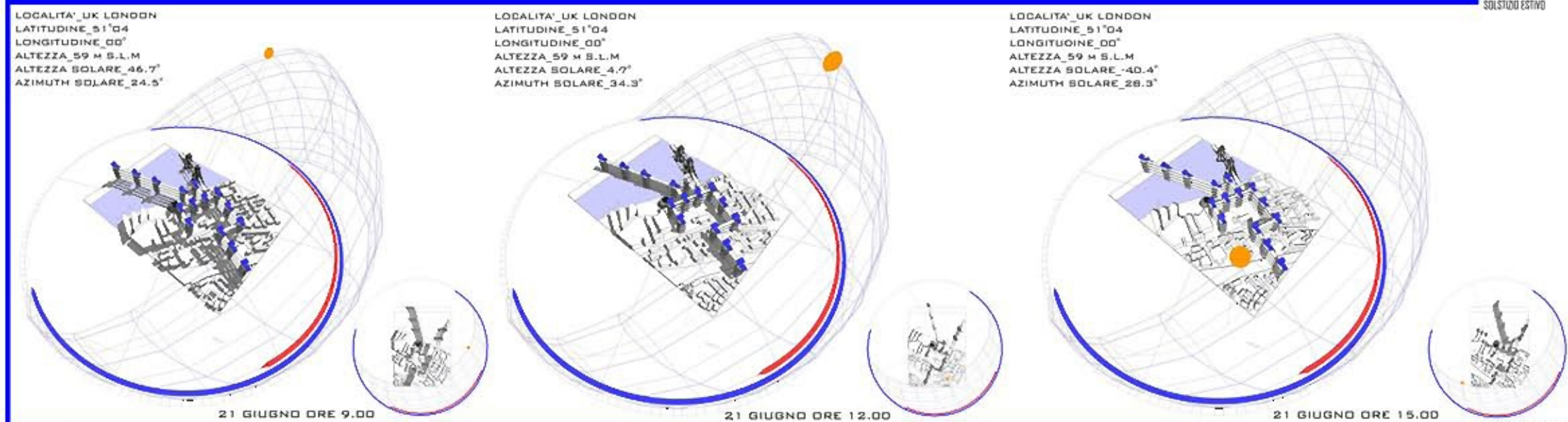

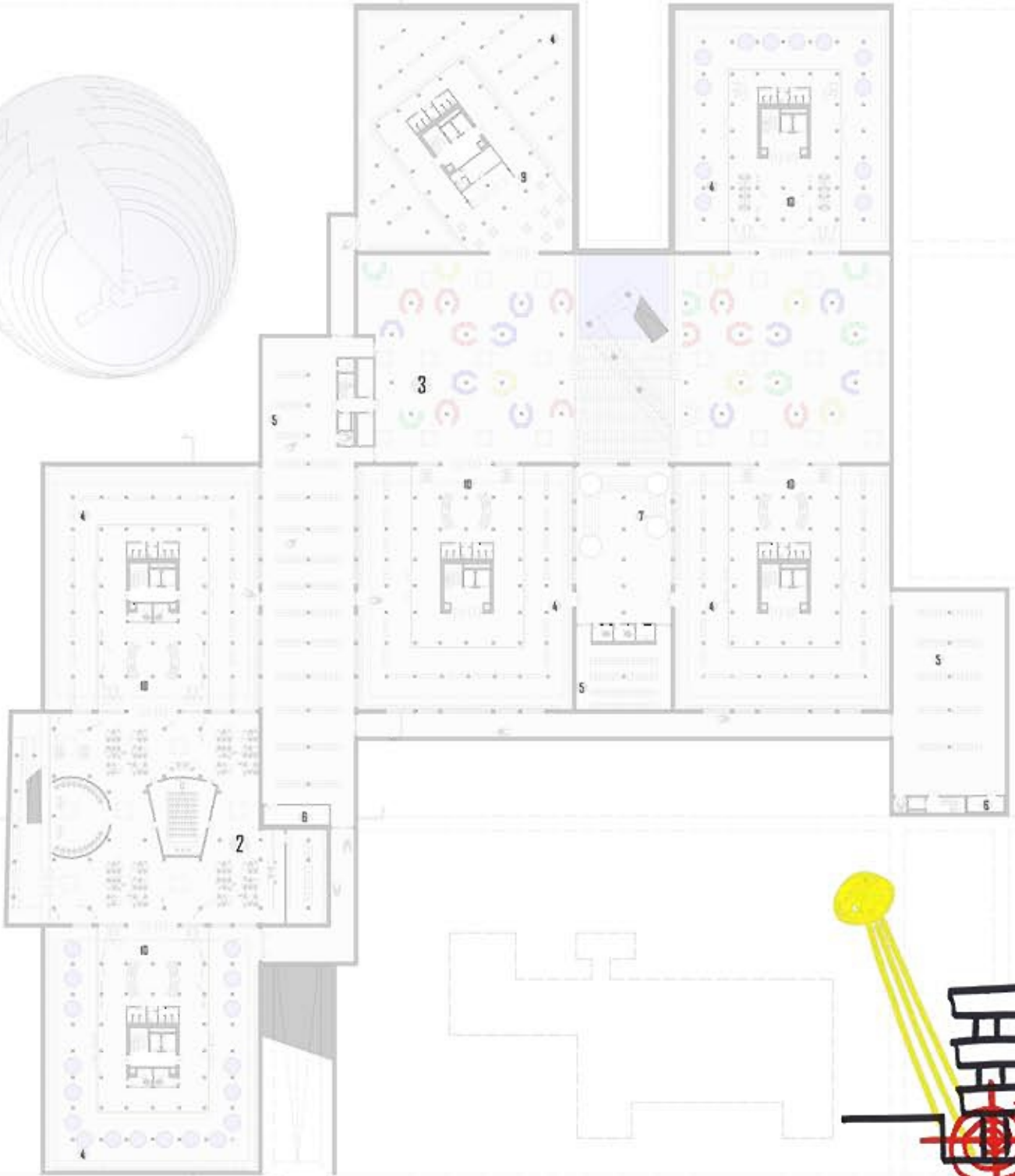

PIANTA(B) LIVELLO -3.50, SCALA 1:500

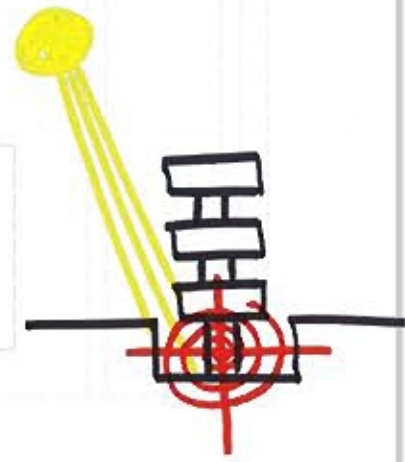

SCHEMI FUNZIONALI

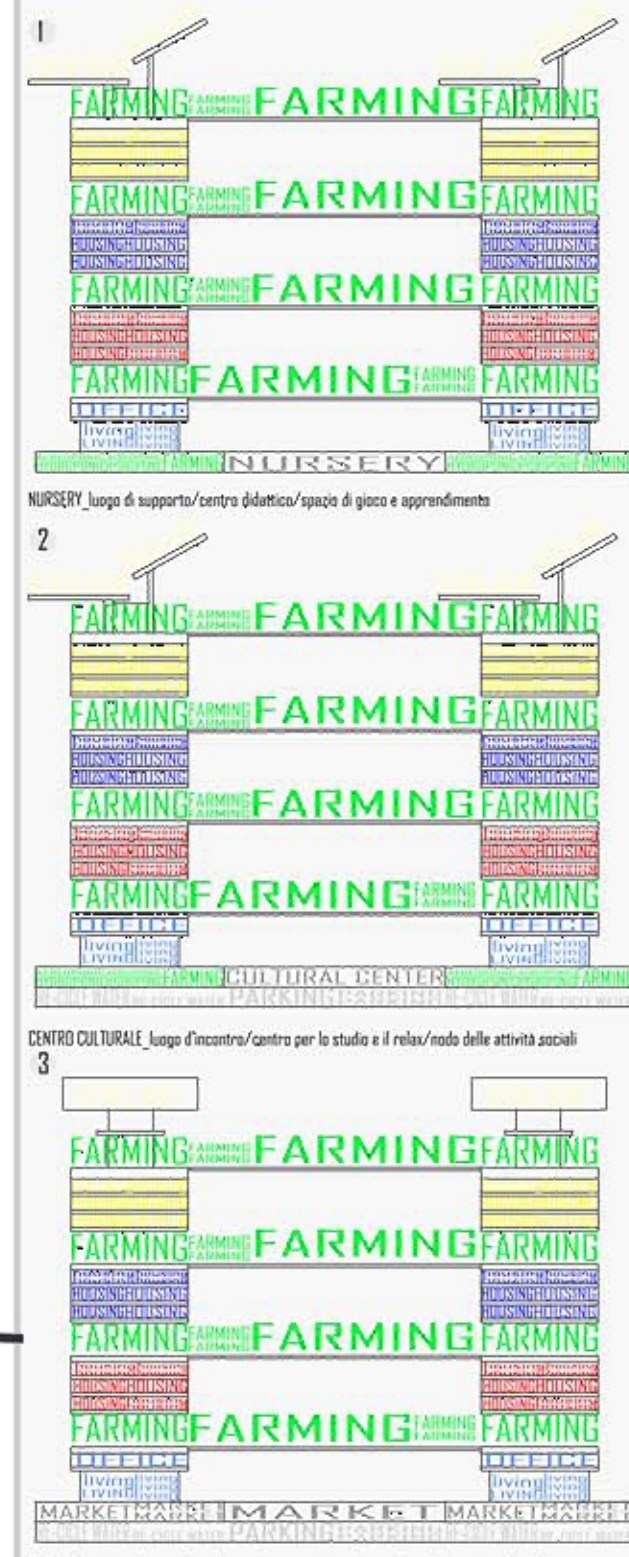

NURSERY luogo di supporto/centro didattico/spazio di gioco e apprendimento

CENTRO CULTURALE luogo d'incontro/centro per lo studio e il relax/nodo delle attività sociali

MARKET spazio per la socialità/centro d'aggregazione/luogo di vendita/spazio adattabile

LA STRATEGIA DELLE COLTURE INDOOR



COSA SI PRODUCE?



COME SI PRODUCE: IDROPONICA/AQUAPONICA/AEROPONICA



VANTAGGI DEI SISTEMI DI COLTIVAZIONE INDOOR
- Con questa tecnica è possibile ottenere una produzione maggiore a parità di superficie coltivata
- inoltre può essere impiegata come alternativa in qualsiasi luogo in cui, per motivi di scarsa fertilità del suolo, non è possibile utilizzare metodi di agricoltura tradizionali.
- Il tempo di crescita della pianta, indipendente dalle stagioni (ciclo continuo), è lo stesso delle coltivazioni tradizionali in terra, però senza interruzioni (nessun periodo di riposo).
- Tecnologie all'avanguardia nel campo della coltivazione aeroponica ai più' utilizzare l'intero volume disponibile e modificare i parametri della soluzione nutritiva in modo da ottenere i migliori risultati colturali.
- consente di poter allevare pesce e ortaggi freschi e naturali per il consumo familiare o addirittura per generare reddito con una propria attività imprenditoriale



CULTURAL CENTER_ESPLOSO SCALA 1:500



MARKET_ESPLOSO SCALA 1:500



NURSERY_ESPLOSO SCALA 1:500



HOUSING SOCIALE E COLLABORATIVO

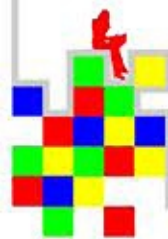
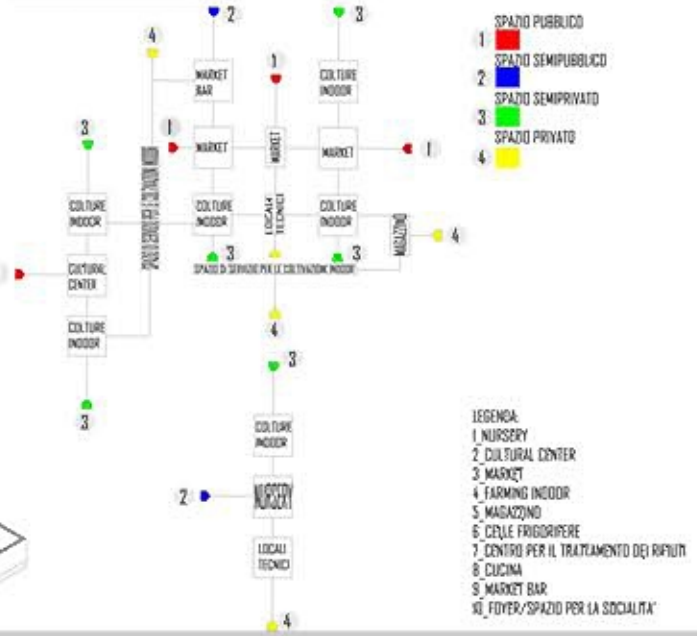

SOCIAL NETWORK



QUERCA/QUERCUS ROBUR
ALTEZZA MAX 45 metri
pianta decidua adatta a climi freddi e umidi

CASTAGNO/CASTANEA SATIVA
ALTEZZA MAX 30 metri
foglie caduche
climi umidi e freddi



FRASSINO/FRAXINUS
ALTEZZA MAX 25 metri
ripulisce da agenti atmosferici come il vento

ACERO/ACER SACCHARINUM
ALTEZZA MAX 10 metri
albero sempre verde
colore giallo-rosso in autunno



CILIEGNO/PRUNUS AVALUM
ALTEZZA MAX 20 metri
albero deciduo da frutto

NOCCIE/JUNGLAS REATA
ALTEZZA MAX 30 metri

PRUGNA/PRUNUS DOMESTICA
ALTEZZA MAX 10 metri
albero da frutto

LEGENDA alberature

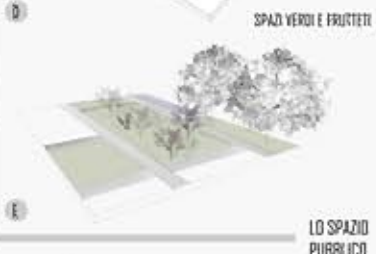
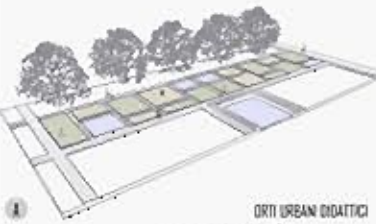

PERCORSI PEDONALI E CICLABILI
SPAZI PER LA SOCIALITA'
ORTI URBANI A SCOPO DIDATTICO
SPAZI VERDI
ACCESSI PEDONALI E CARRABILI
SPECCHI D'ACQUA

LEGENDA

- ▲ ACCESSO PEDONALE DALLO SPAZIO PUBBLICO
- ▲ ACCESSO CARRABILE
- 1- BUS STOP E AGENCY FOR WORK
- 2- COMMUNITY SPACE_AREE PER IL TEMPO LIBERO
- 3- MEDIATECA
- 4- BAR
- 5- COLTIVAZIONI INDOOR
- 6- INFOPOINT
- 7- LITTLE PIER

LOFT

london farm tower



PIANTA PIANI TERRA SCALA 1:1000

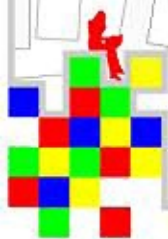

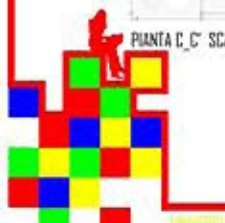
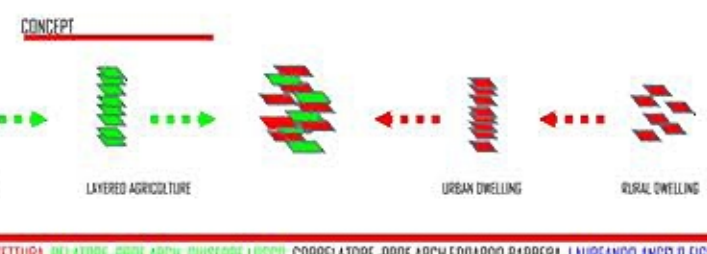
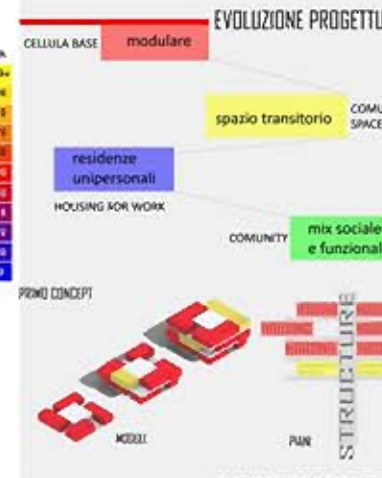
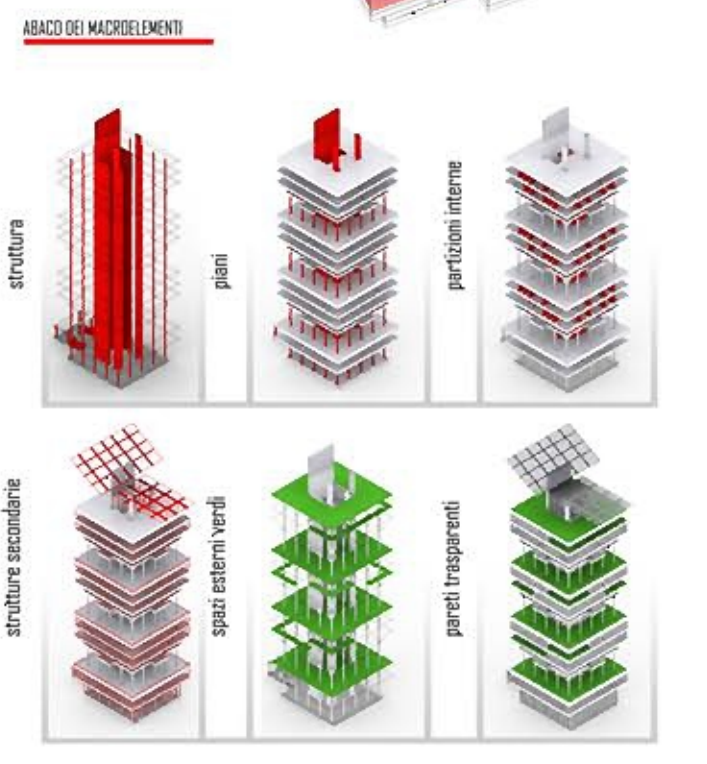
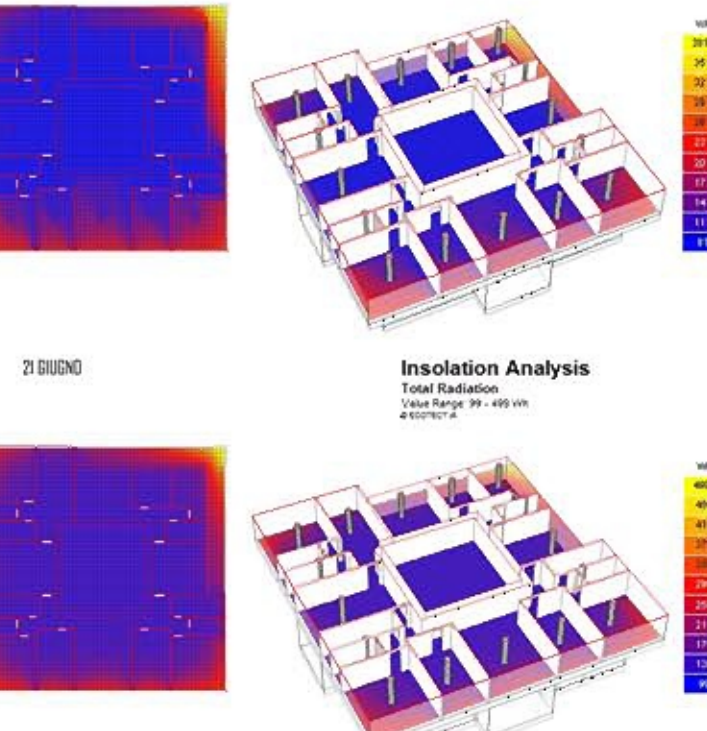
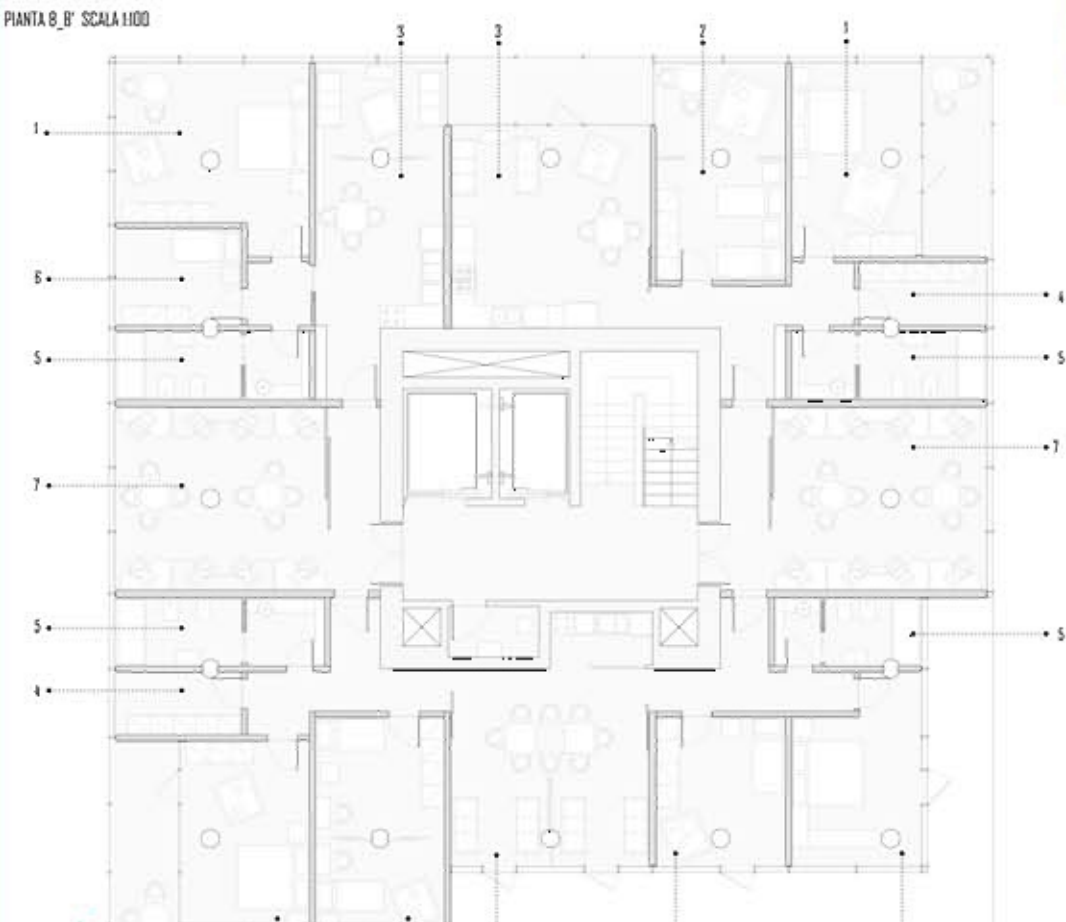
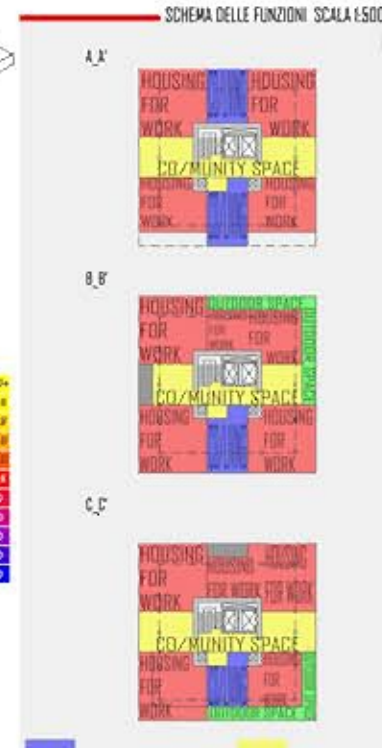
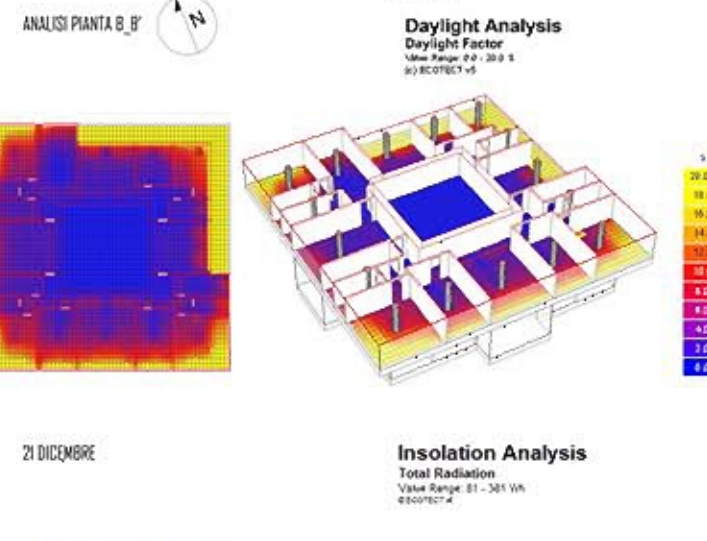
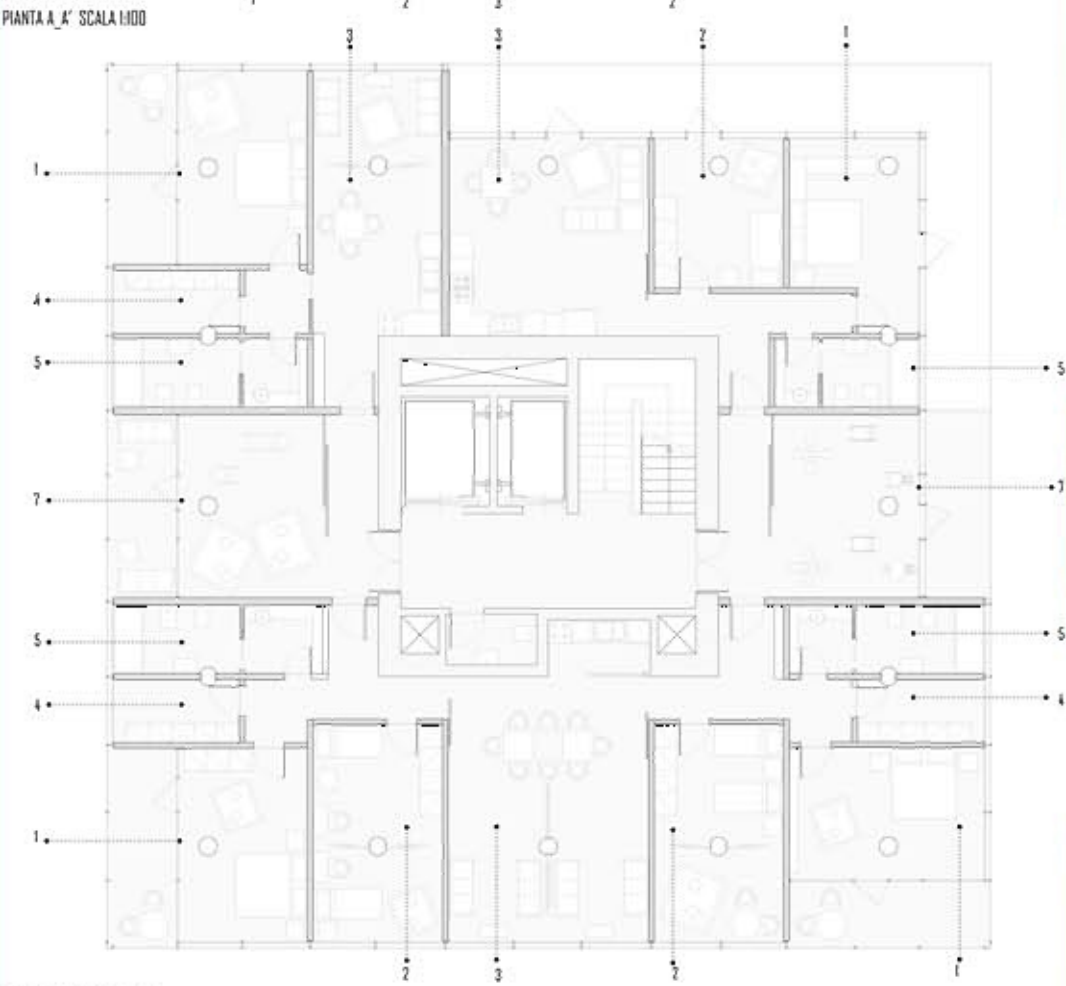
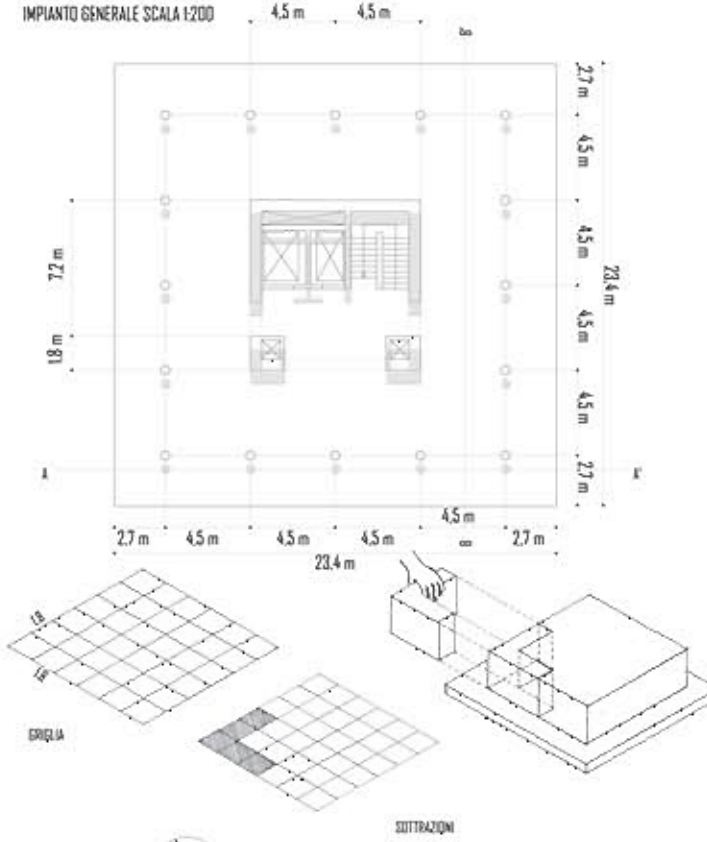
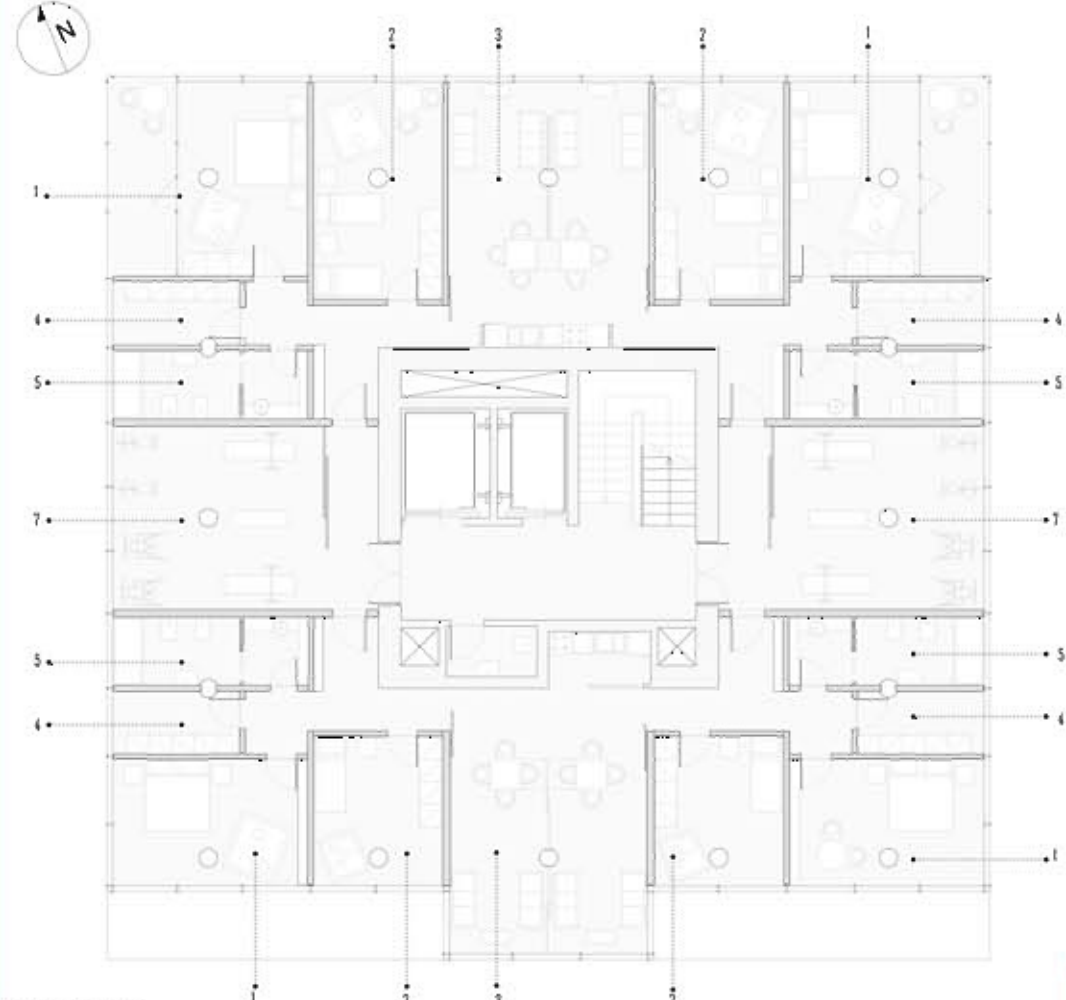

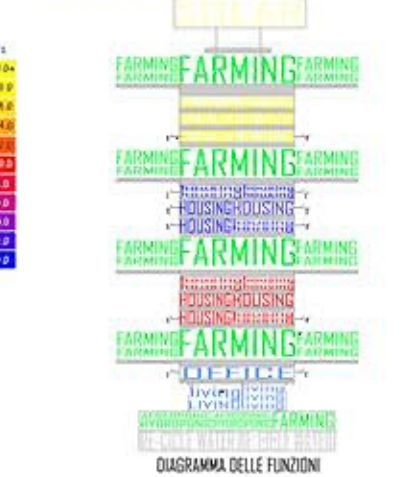
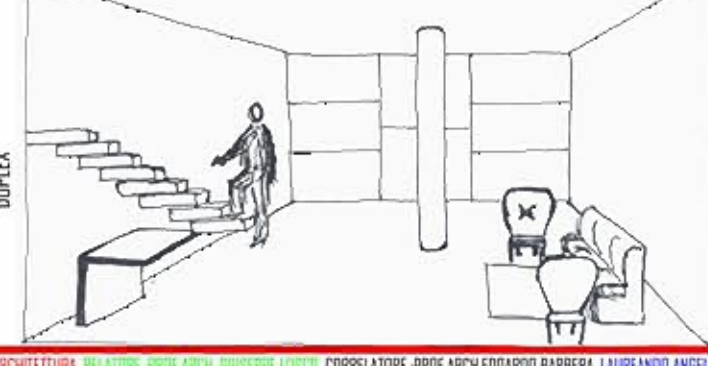
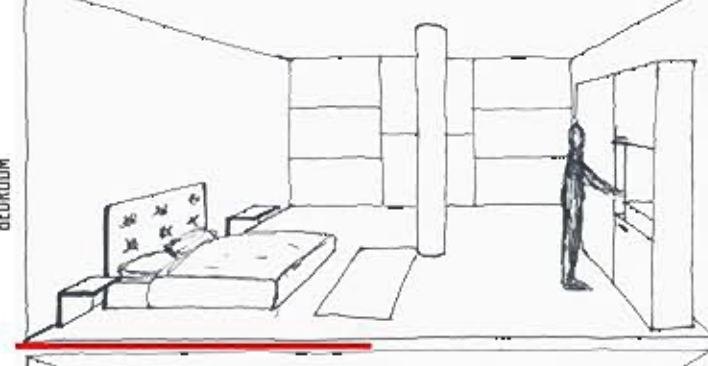
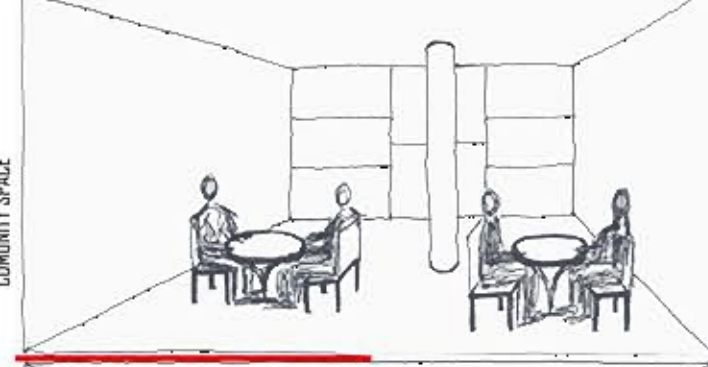
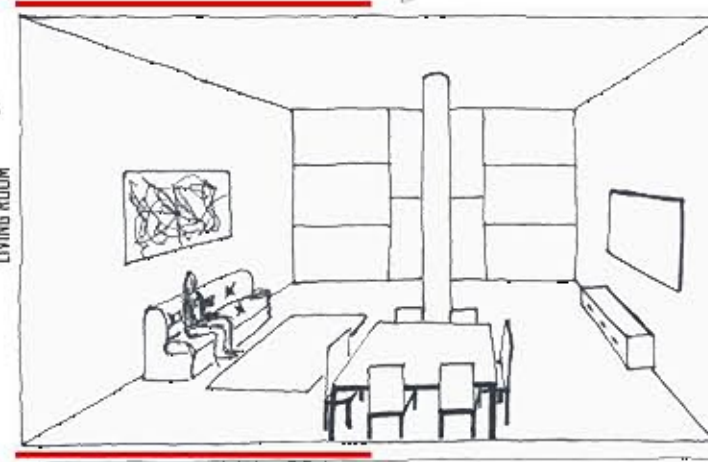
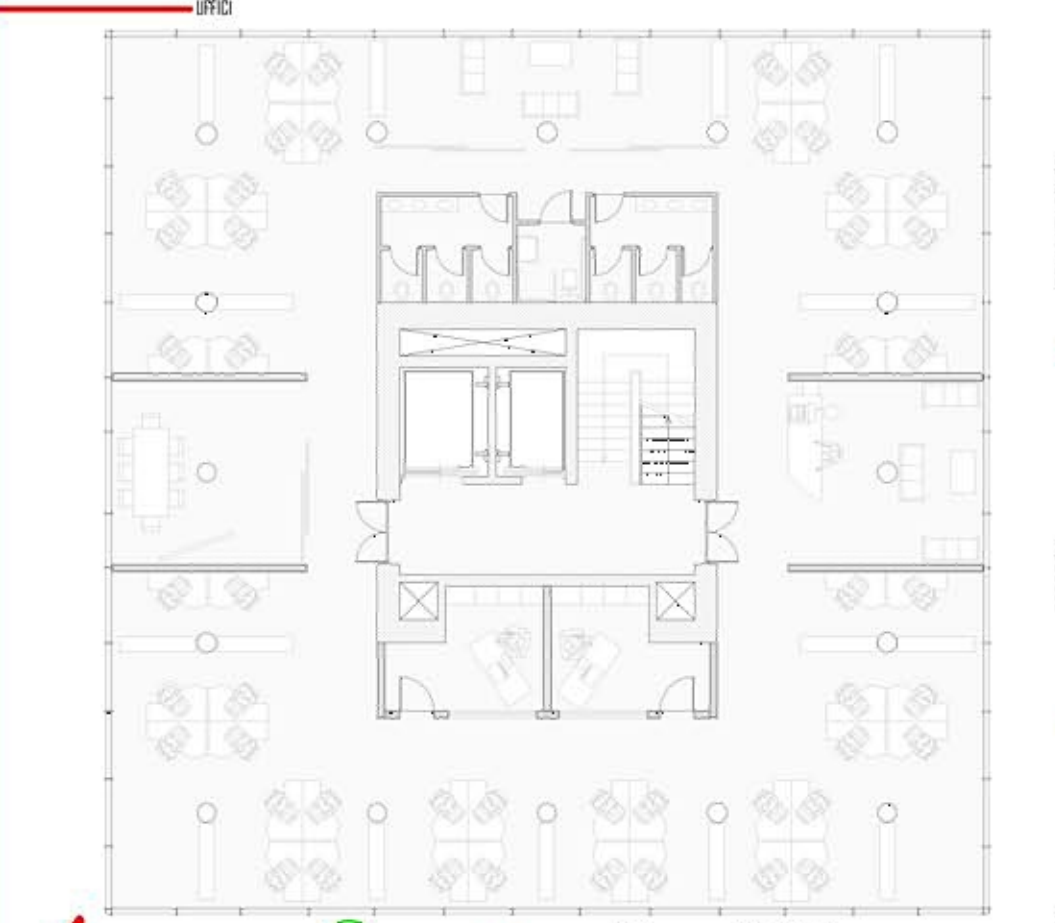
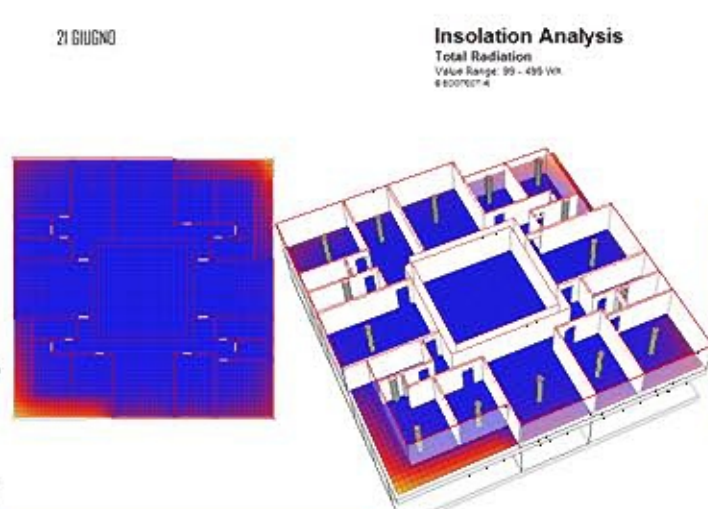
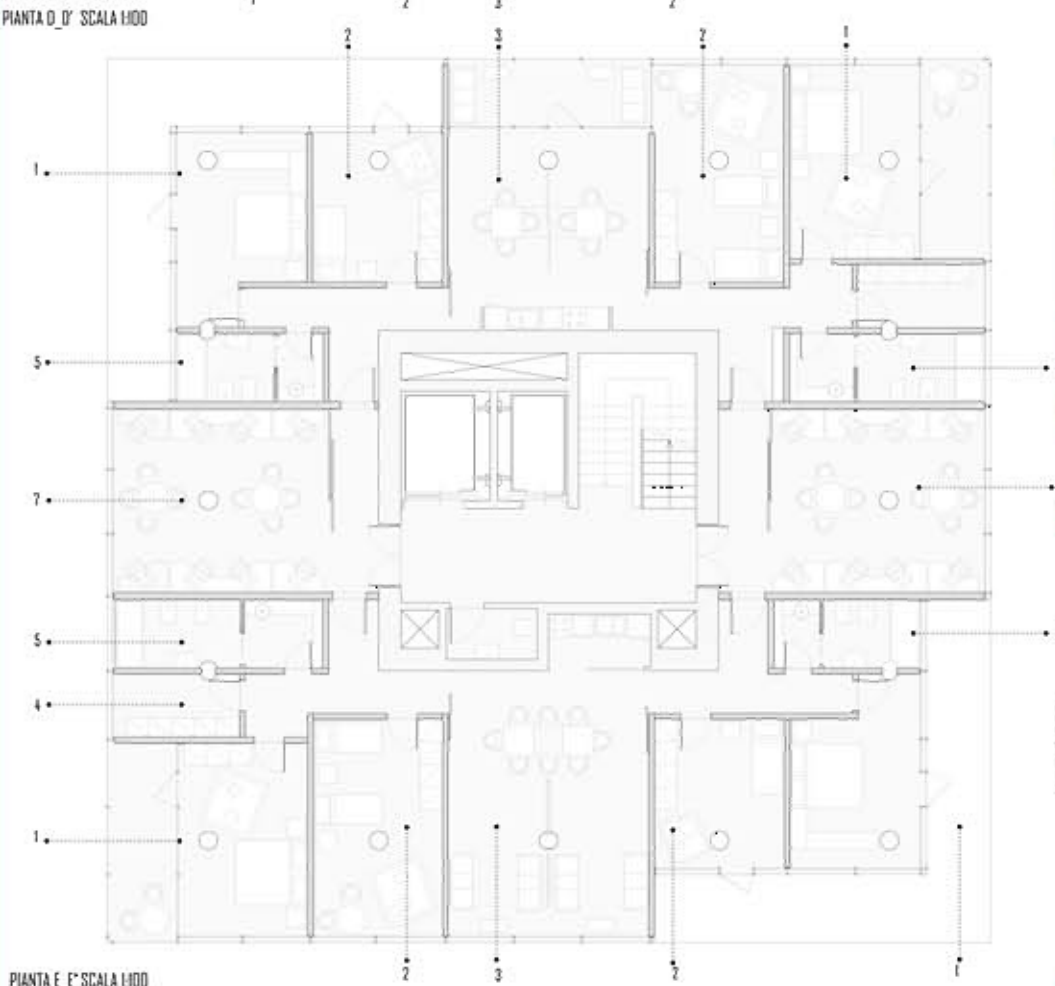
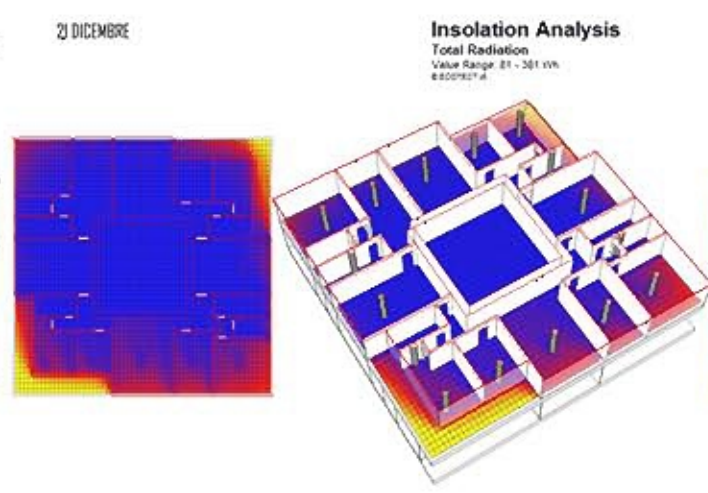
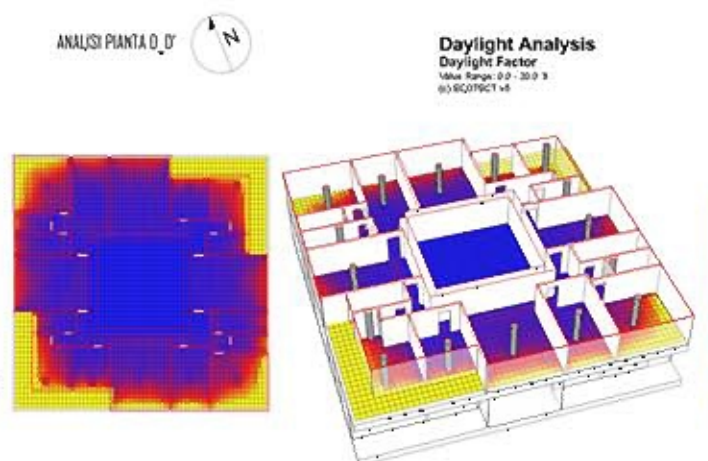
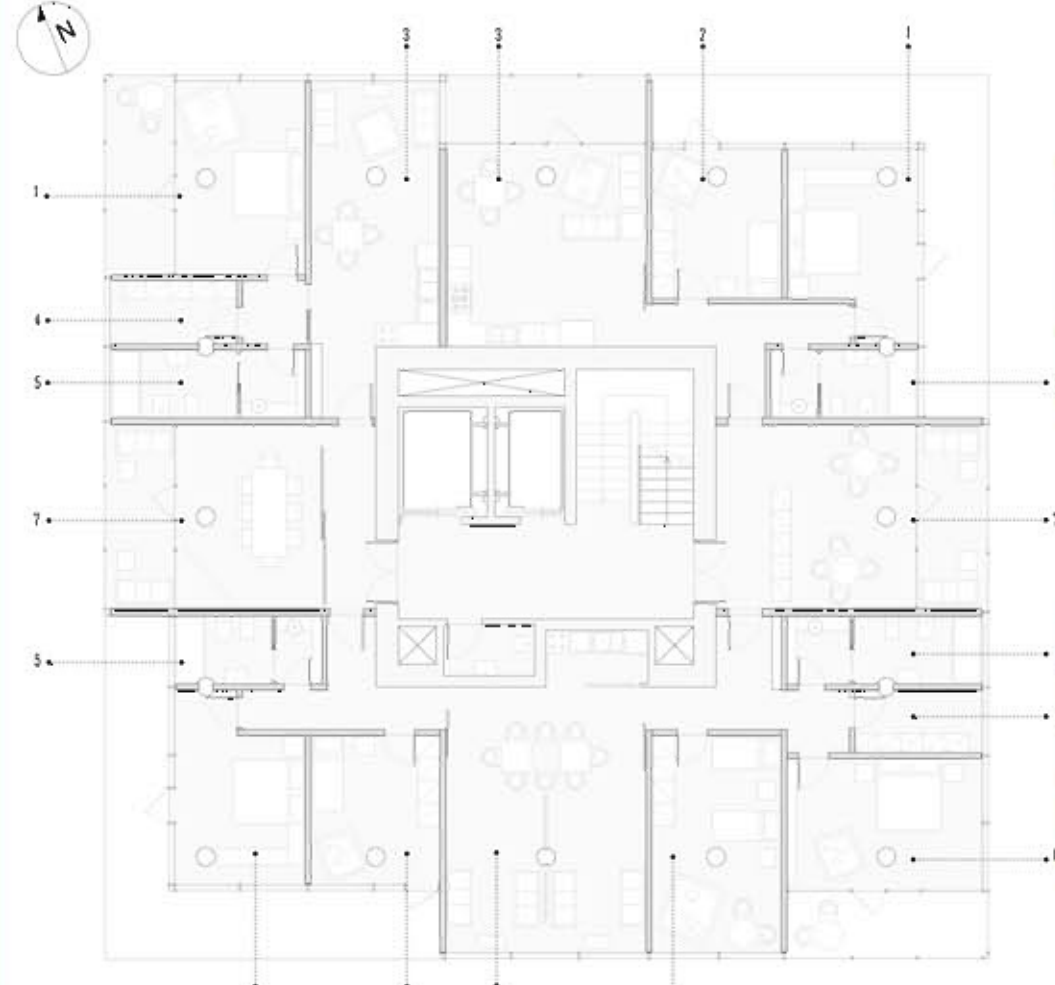

SCHEMA DELLE FUNZIONI SCALA 1:500

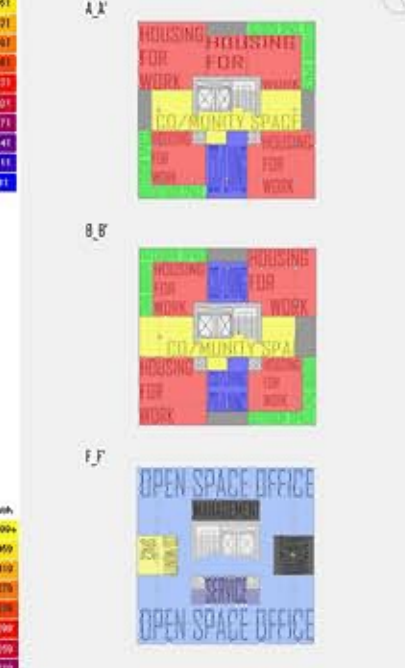

- CO/LIVING
 - HOUSING FOR WORK
 - SOLAR GREENHOUSES
 - CO/MUNITY SPACE
 - OUTDOOR SPACE
 - OPEN SPACE OFFICE
 - MANAGEMENT
 - SERVICE
- LEGENDA

- CAMERA DOPPIA/MATRIMONIALE O DOPPIA LETTI SINGOLI
- CAMERA DOPPIA O SINGOLA
- CUCINA +LIVING ROOM
- CABINA ARMADIO
- BAGNO
- CAMERA SINGOLA
- COMMUNITY SPACE



LINEE GUIDA DI SVILUPPO
-PROGETTO URBANO, LINEE GUIDA DI SVILUPPO URBANO



I DATI DEL PROGETTO

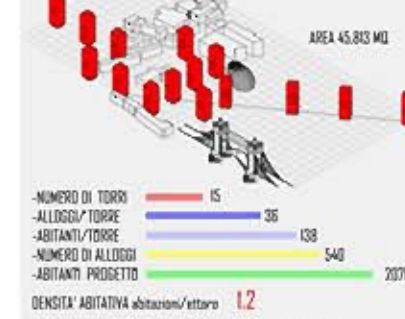

- TIPOLOGIE ABITATIVE
- ALLOGGI A CANONE CALMIERATO: 38%
 - EGILIZIA ASSISTENZIALE: 30%
 - ALLOGGI IN VENDITA DIRETTA: 19%
 - ALLOGGI IN VENDITA DIFFERITA: 13%

LOFT

PIANTA F_3' SCALA 1:100

OFFICI

PROF. ARCH. GIUSEPPE LUDIGI

SCUOLA D'ARCHITETTURA E DESIGN, ANNO ACCADEMICO 2010/11, TESI DI LAUREA IN PROGETTAZIONE AMBIENTALE DELL'ARCHITETTURA

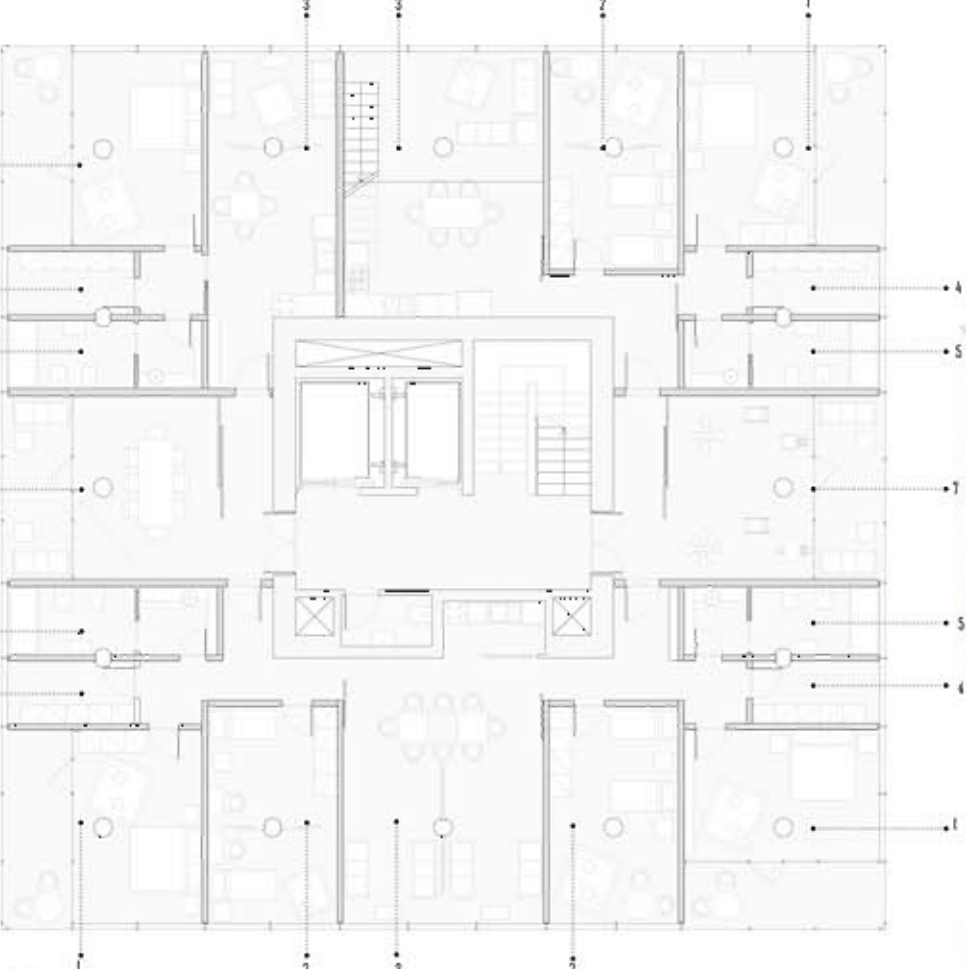

ANALISI PIANTA 0_0'

Daylight Analysis
Daylight Factor
Value Range: 0.0 - 20.0
@SCOTECT v5

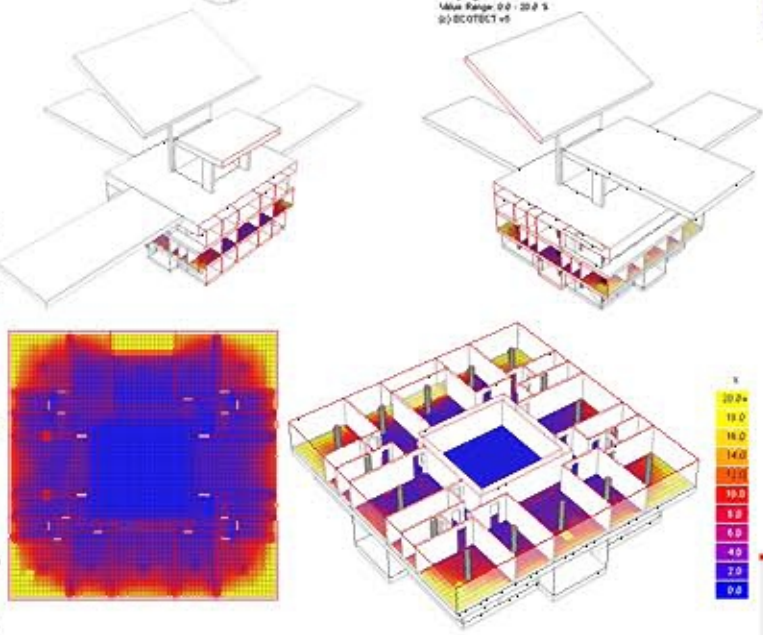

21 DICEMBRE

Insolation Analysis
Total Radiation
Value Range: 81 - 385 Wh
@SCOTECT v5

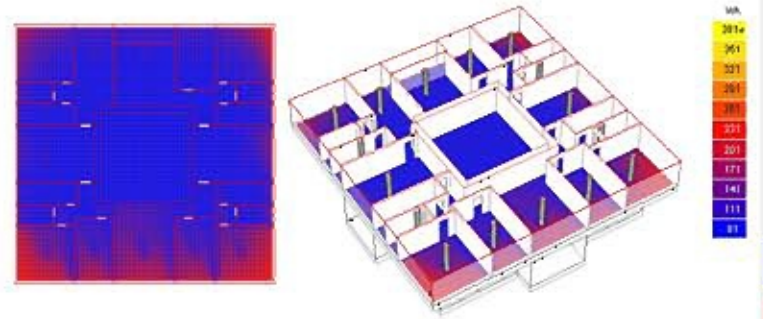

21 GIUGNO

Insolation Analysis
Total Radiation
Value Range: 99 - 495 Wh
@SCOTECT v5

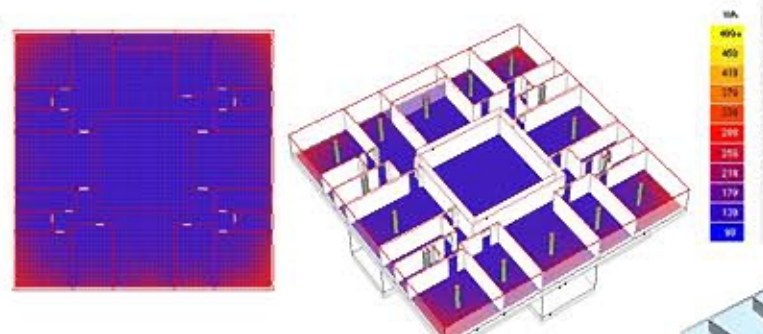

SCHEMA DELLE FUNZIONI SCALA 1:500



- CO/LIVING
- HOUSING FOR WORK
- OUTDOOR SPACE
- CO-MUNITY SPACE
- SOLAR GREENHOUSES

- LEGGENDA
- 1. CAMERA DOPPIA/MATRIMONIALE O DOPPIA LETTI SINGOLI
 - 2. CAMERA DOPPIA O SINGOLA
 - 3. CUCINA -LIVING ROOM
 - 4. CABINA ARMADIO
 - 5. BAGNO
 - 6. CAMERA SINGOLA
 - 7. COMUNITY SPACE

PIANTA G_0' SCALA 1:100

PIANTA H_1F SCALA 1:100

LEGGENDA SPAZI COMUNI

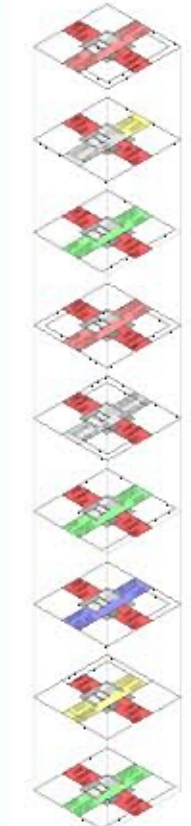

LOFT

london farm tower

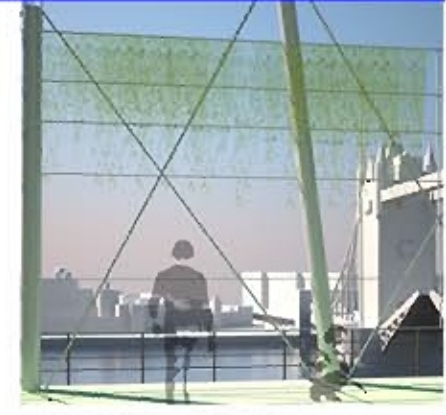
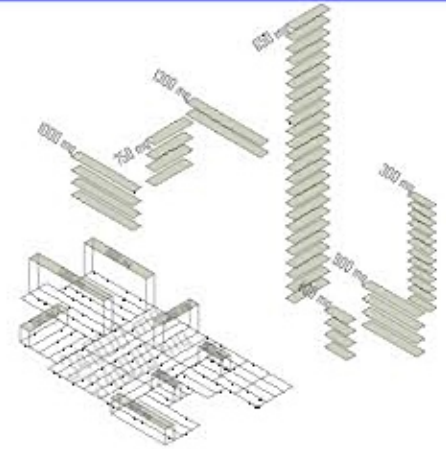
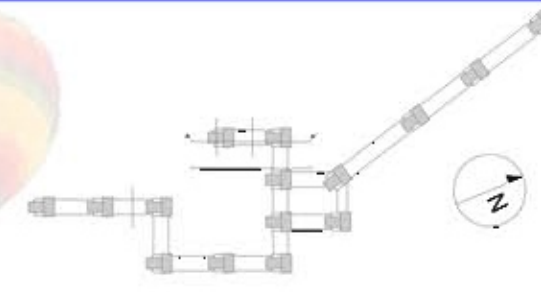

NUOVI TERRENI COLTIVABILI

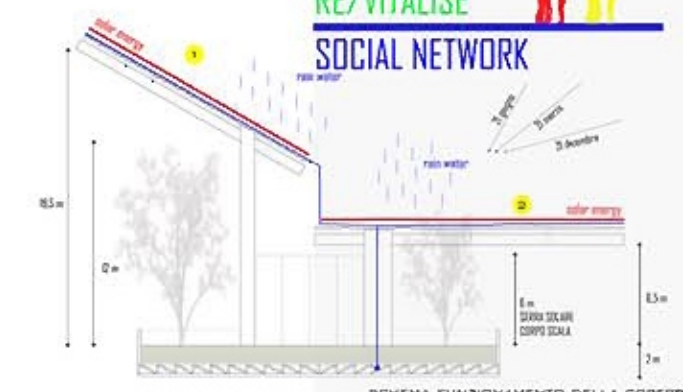

RE/VITALISE
SOCIAL NETWORK

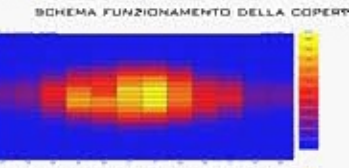

RADIAZIONE SOLARE ANNUA SUPERFICIE 1
AZI: 158.00°, ALT: 64.00°, SUP: 419 M²

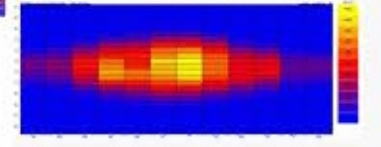

RADIAZIONE SOLARE ANNUA SUPERFICIE 2
AZI: 22.00°, ALT: 90.00°, SUP: 293 M²

RADIAZIONE SOLARE ANNUA SUPERFICIE 1 + SUPERFICIE 2

TIPOLOGIA DEI PANNELLI FOTOVOLTAICI USATI

POTENZA DI PICCO DEL PANNELLO FOTOVOLTAICO 225 Wp

TOTALE 472.824 KW SOLARI x 225 Wp

ENERGIA ELETTRICA ANNUALE PRODOTTA 472.824 KW SOLARI x 225 Wp

TOTALE 106.381 KW ELETTRICI

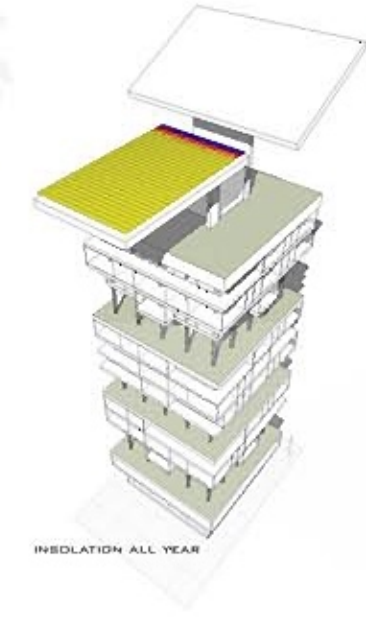

INSOLATION ALL YEAR

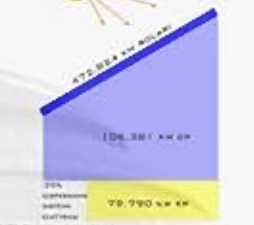

RESA EFFETTIVA ANNUA

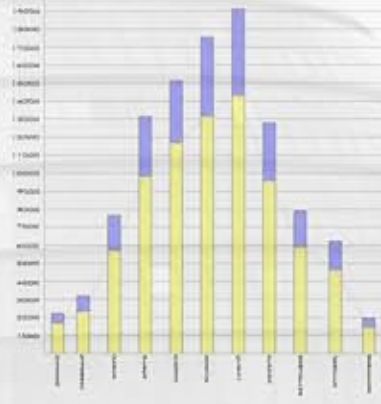

RESA MENSILE DELL'IMPIANTO KW/MESE

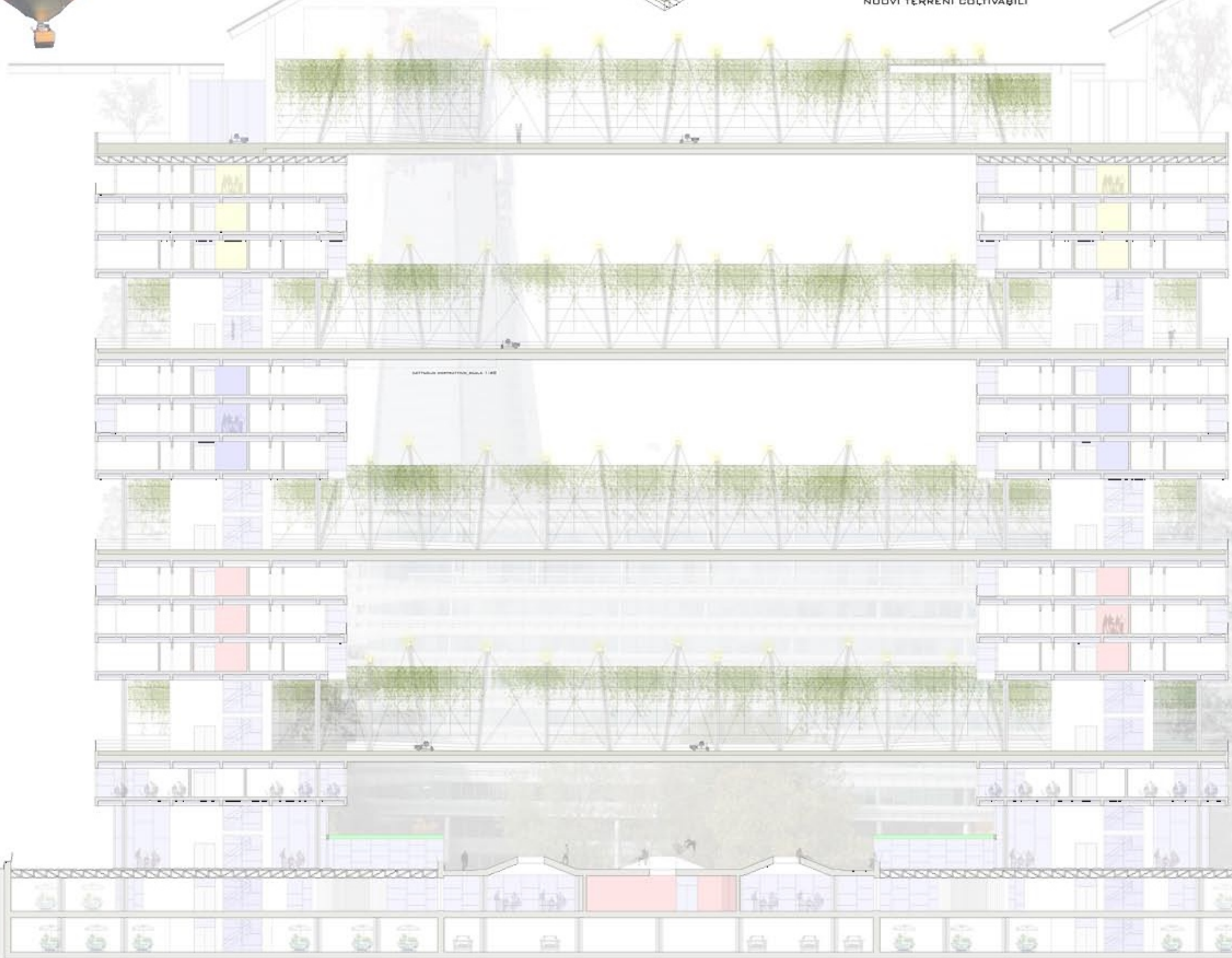

SEZIONE A-A' SCALA 1:200

LOFT

london farm tower

SHADOW RANGE

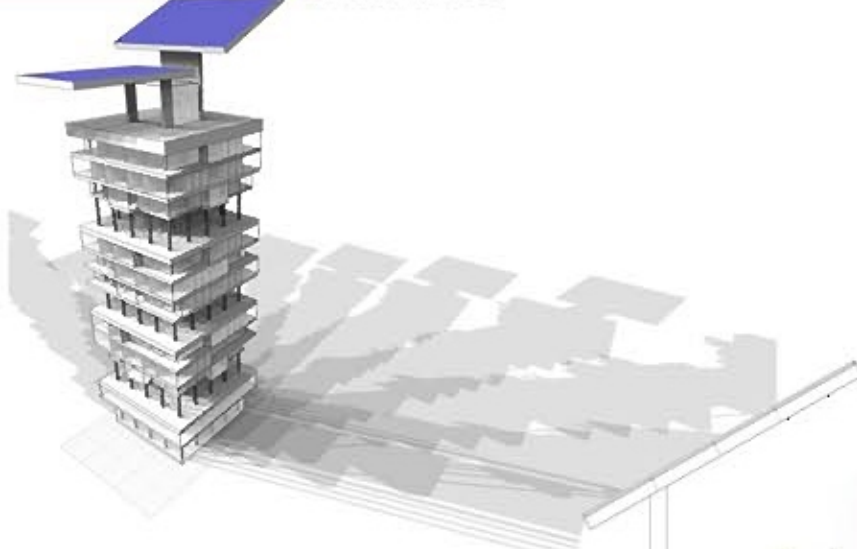

PIANTA DELLE COPERTURE
SCALA 1:200

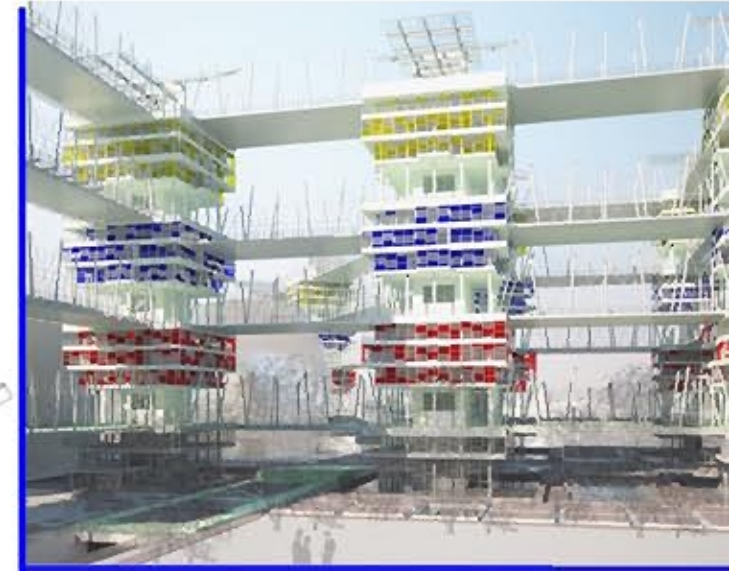
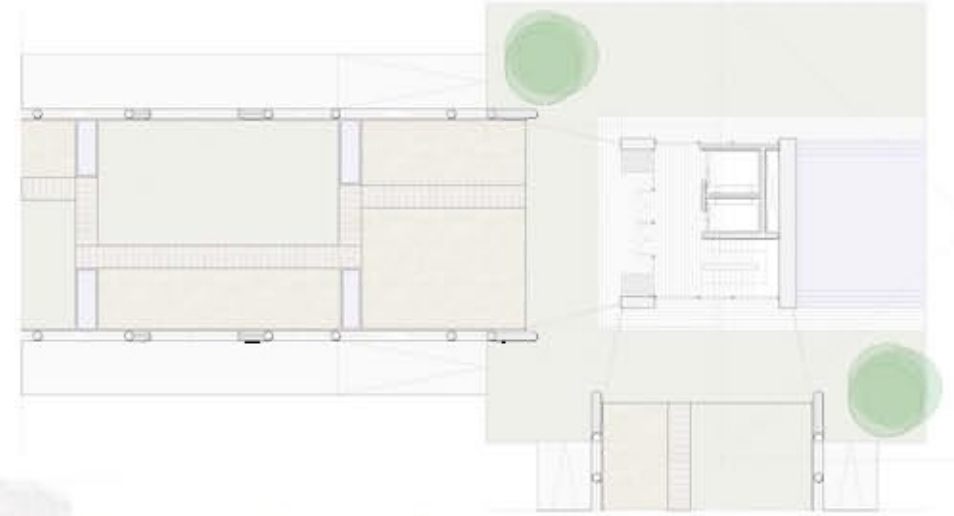

LOFT
london farm tower

15
14
13
12
11
10
9
8
7
6
5
4
3
2
1

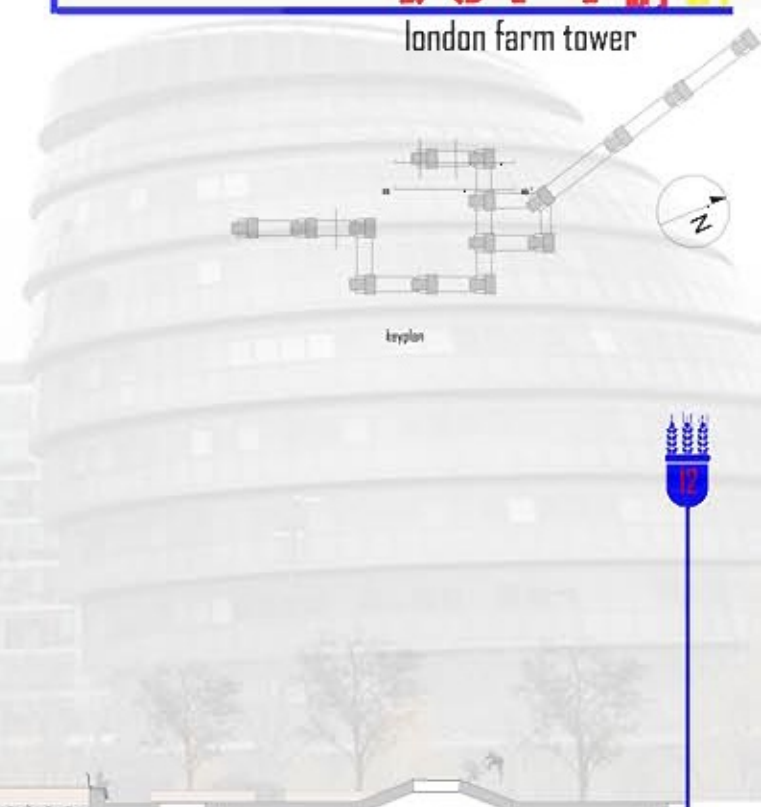
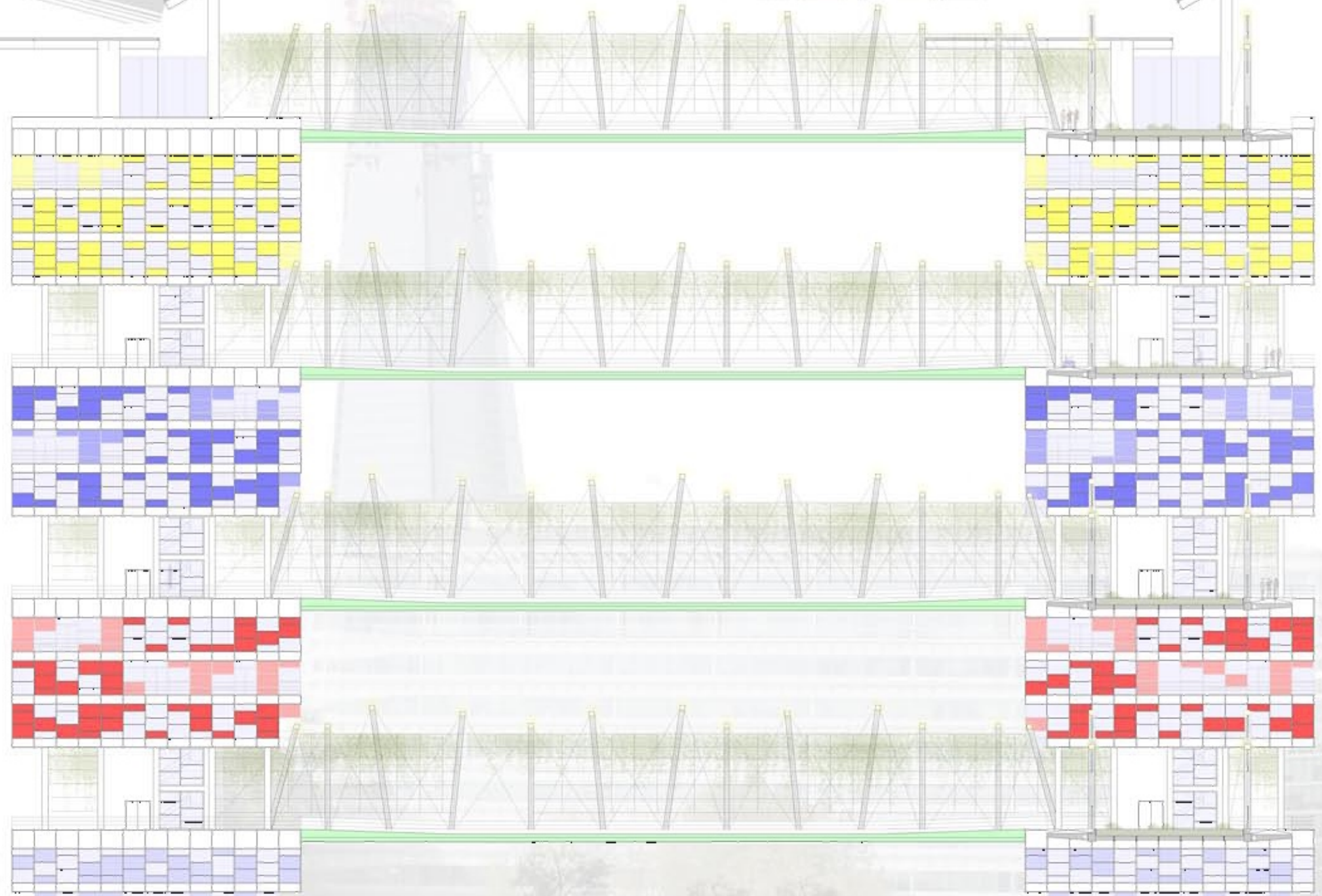

PROSPETTO SUD/EST SCALA 1:200

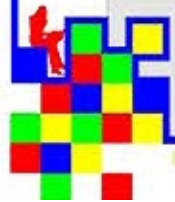

ENERGY
CONSIDERATIONS



- wind turbine
- DC/AC converter
- hydrogen fuel cell
- photovoltaic panel
- battery backup
- methane from biogas machine
- AC current
- DC power
- inverter

ENERGY
CONSIDERATIONS

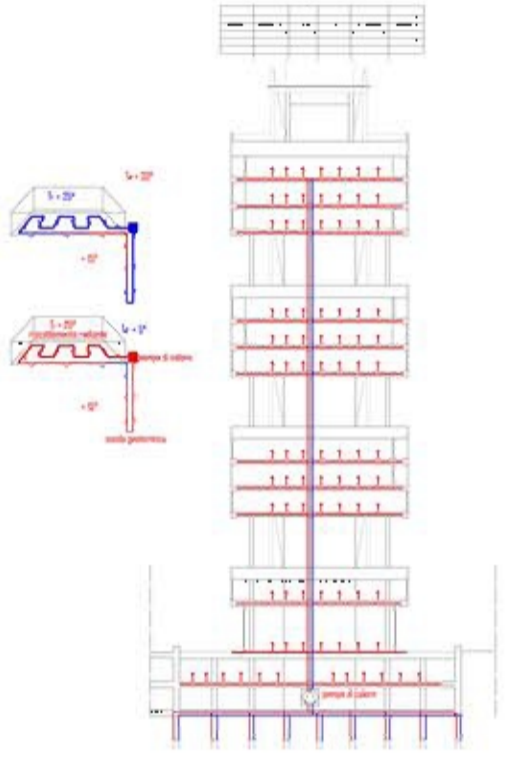

WATER
CONSIDERATIONS

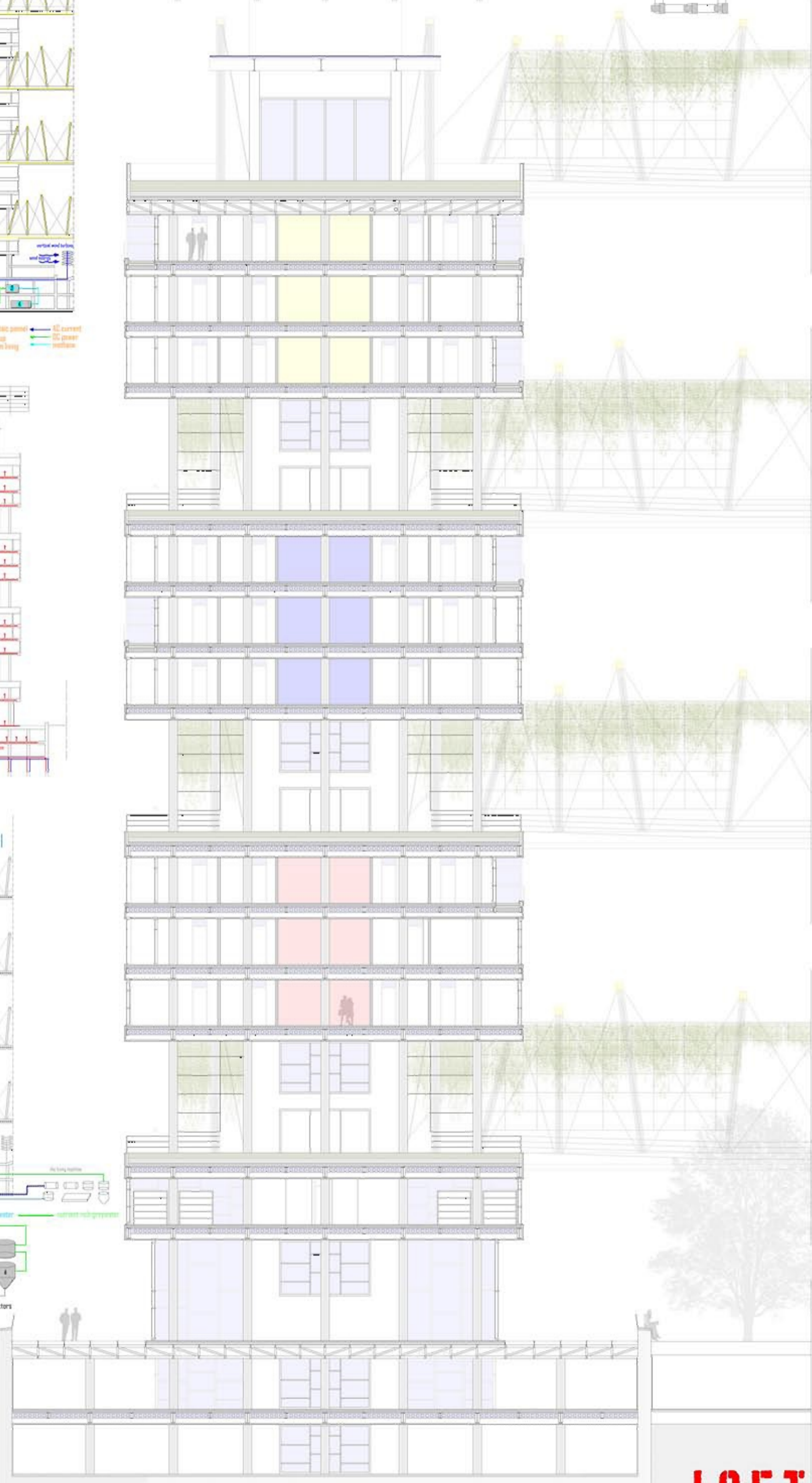
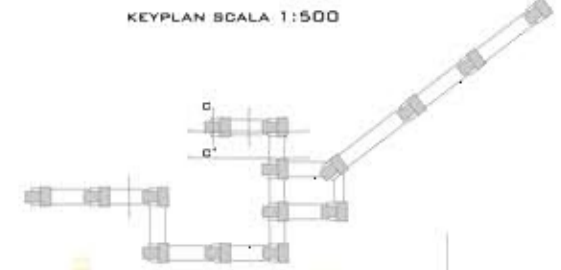
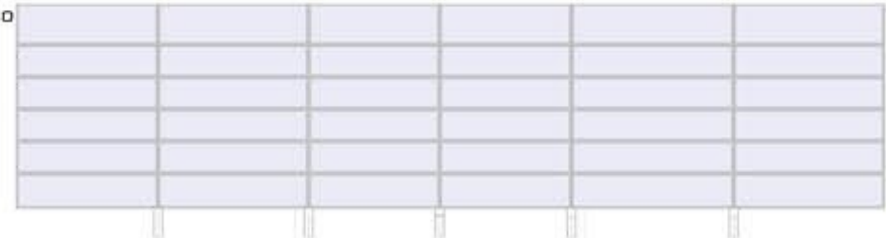
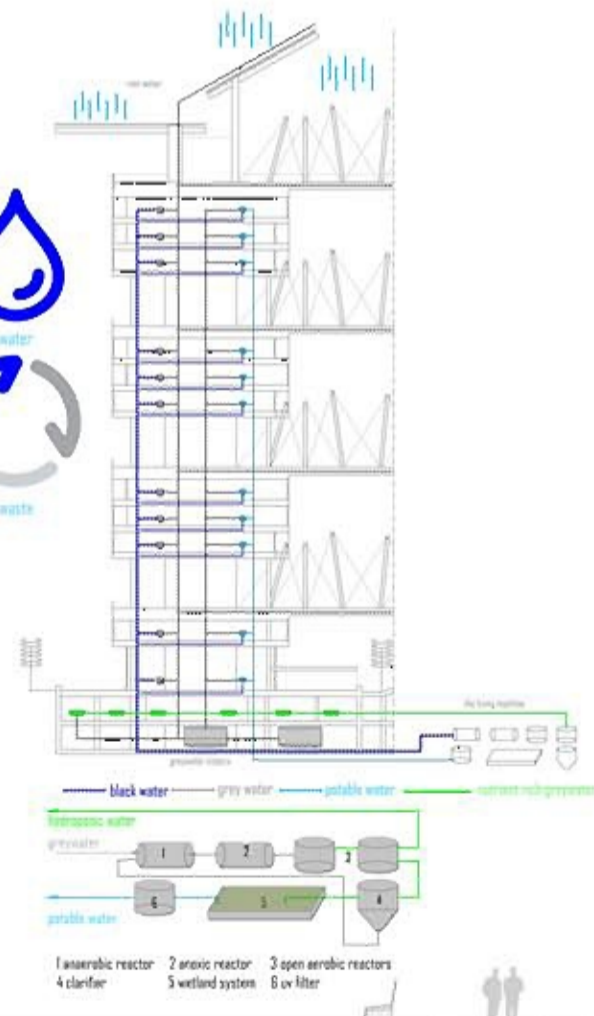

SEZIONE C-C'

LOFT

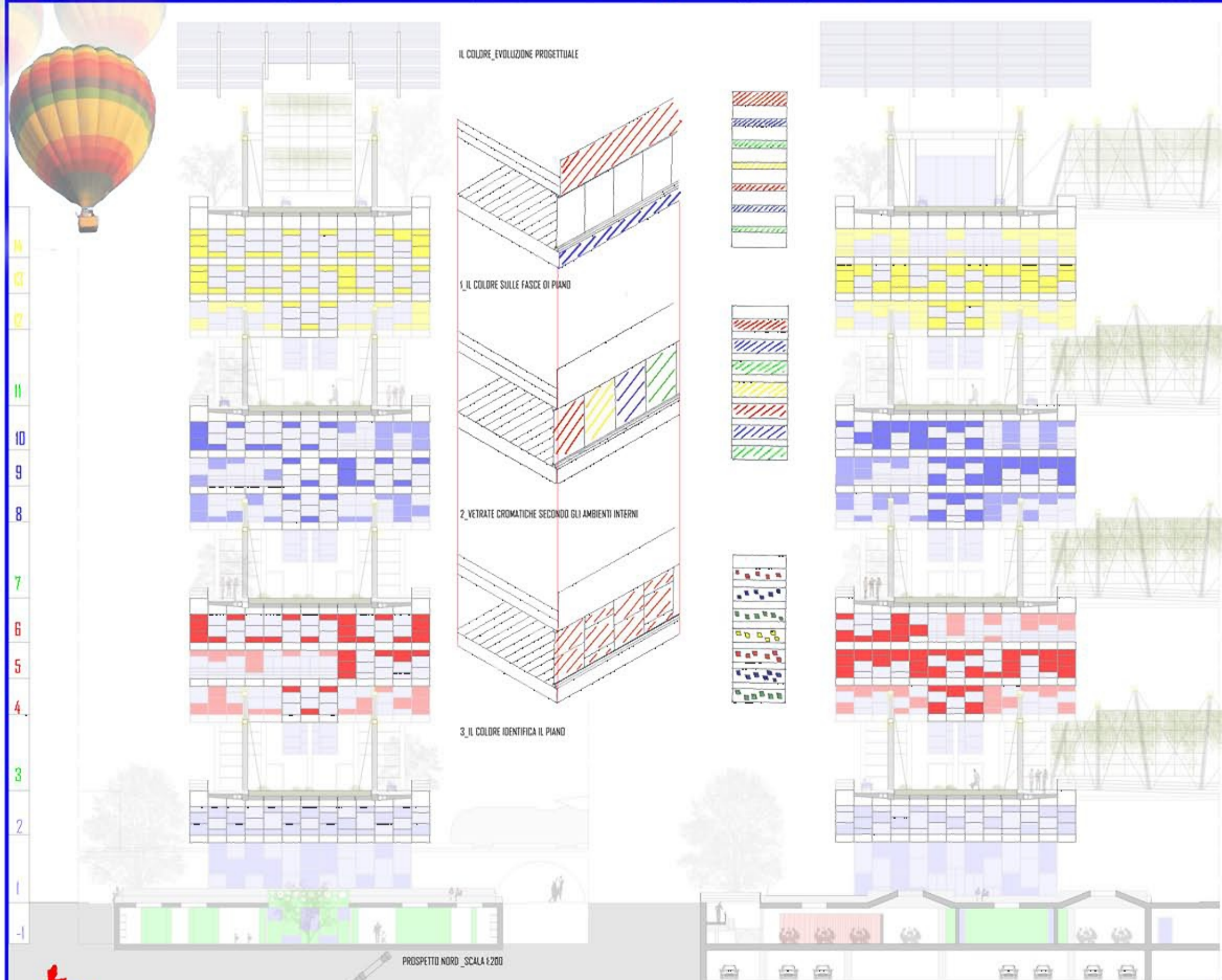
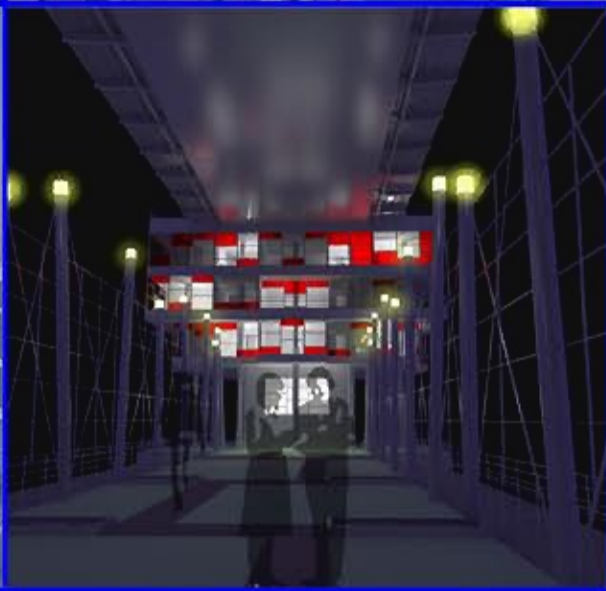
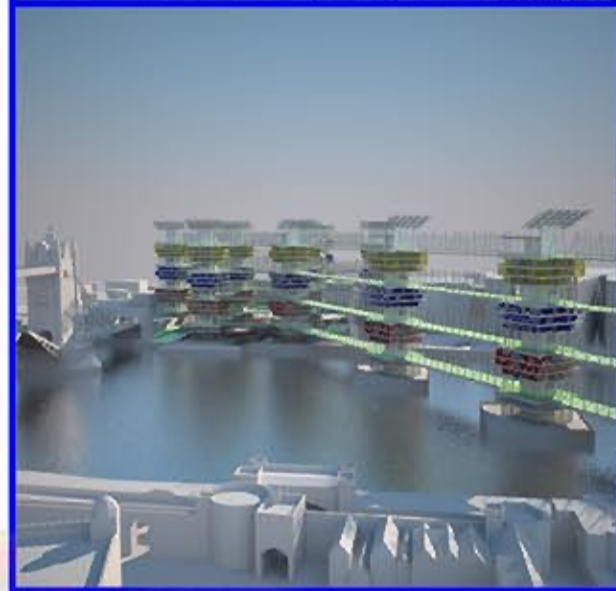
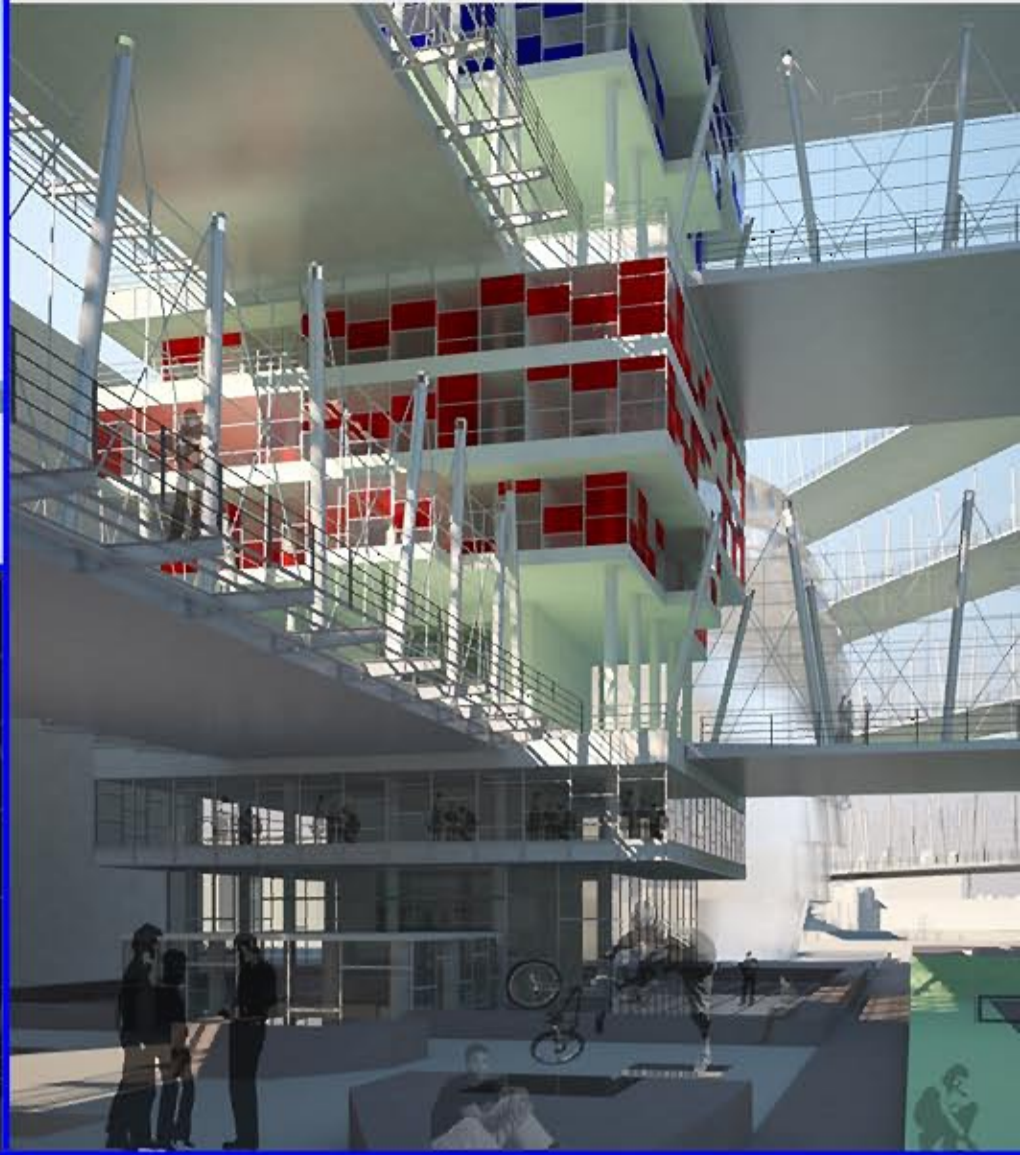
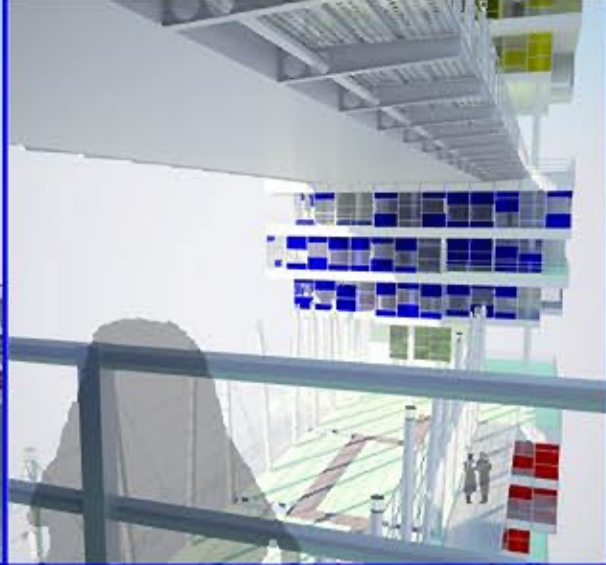
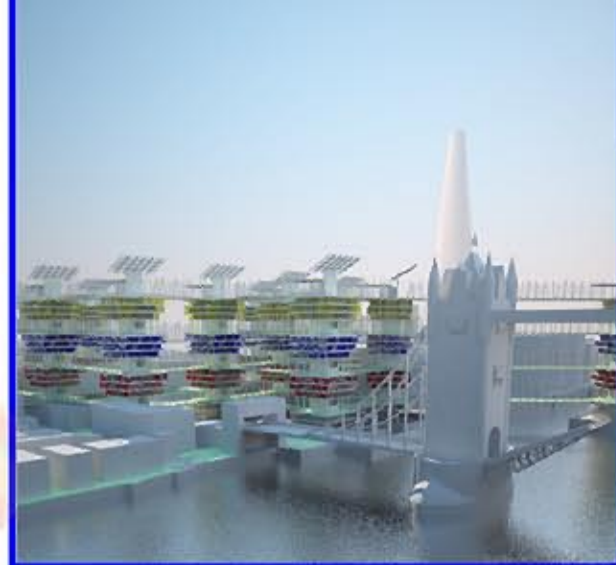

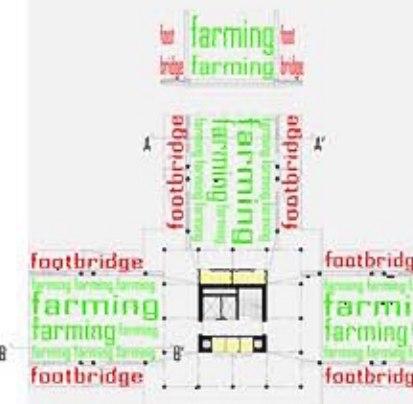

KEY PLAN

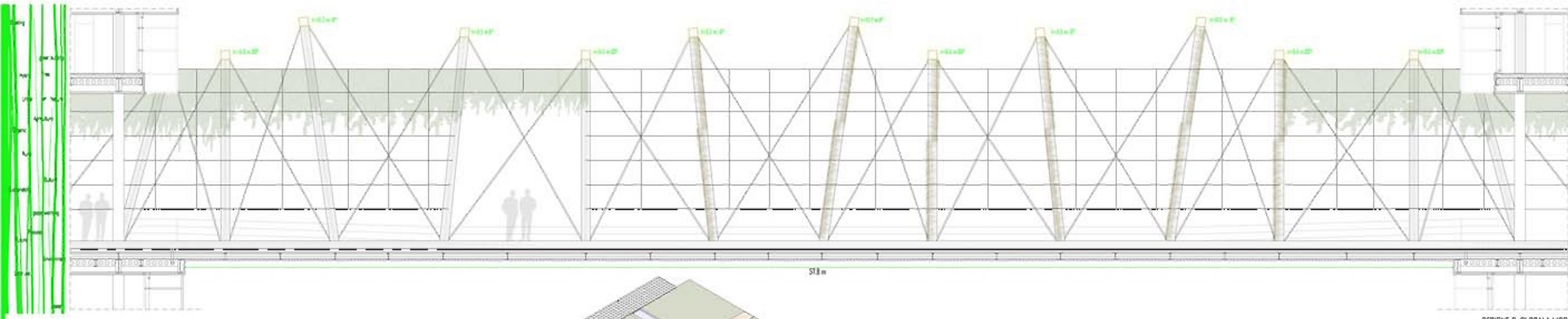

SEZIONE B, B' SCALA 1:100

- SPAZIO SCALA 1:100
- 1. STRUTTURA PRINCIPALE travi accollate 400 mm x 400 mm / pilastri 400 mm / travi 400 mm
 - 2. STRUTTURA SECONDARIA sp. 200
 - 3. STRUTTURA SOTTOCOSTA footbridge
 - 4. LAMIERA GRIGIA sp. 120 mm
 - 5. SOLARE sp. 80 mm
 - 6. MEMBRANA STOMACCA sp. 4 mm
 - 7. CEMENTO sp. 40 mm
 - 8. CEMENTO sp. 40 mm
 - 9. SPINA sp. 100 mm
 - 10. FILTRO ACQUOSITÀ sp. 2 mm
 - 11. MANICO FISSO sp. 40 mm
 - 12. LAMIERA FORATA sp. 40 mm
 - 13. RETE METALLICA sp. 30 mm
 - 14. FARI CONCRETO

SCHEMA APPOGGIO DELLA STRUTTURA

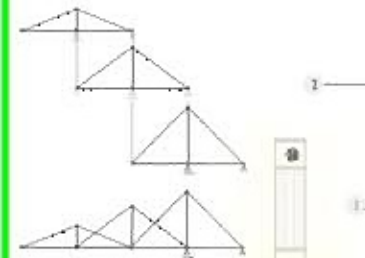
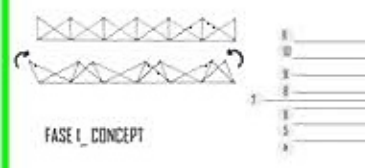

SEZIONE A, A' SCALA 1:50

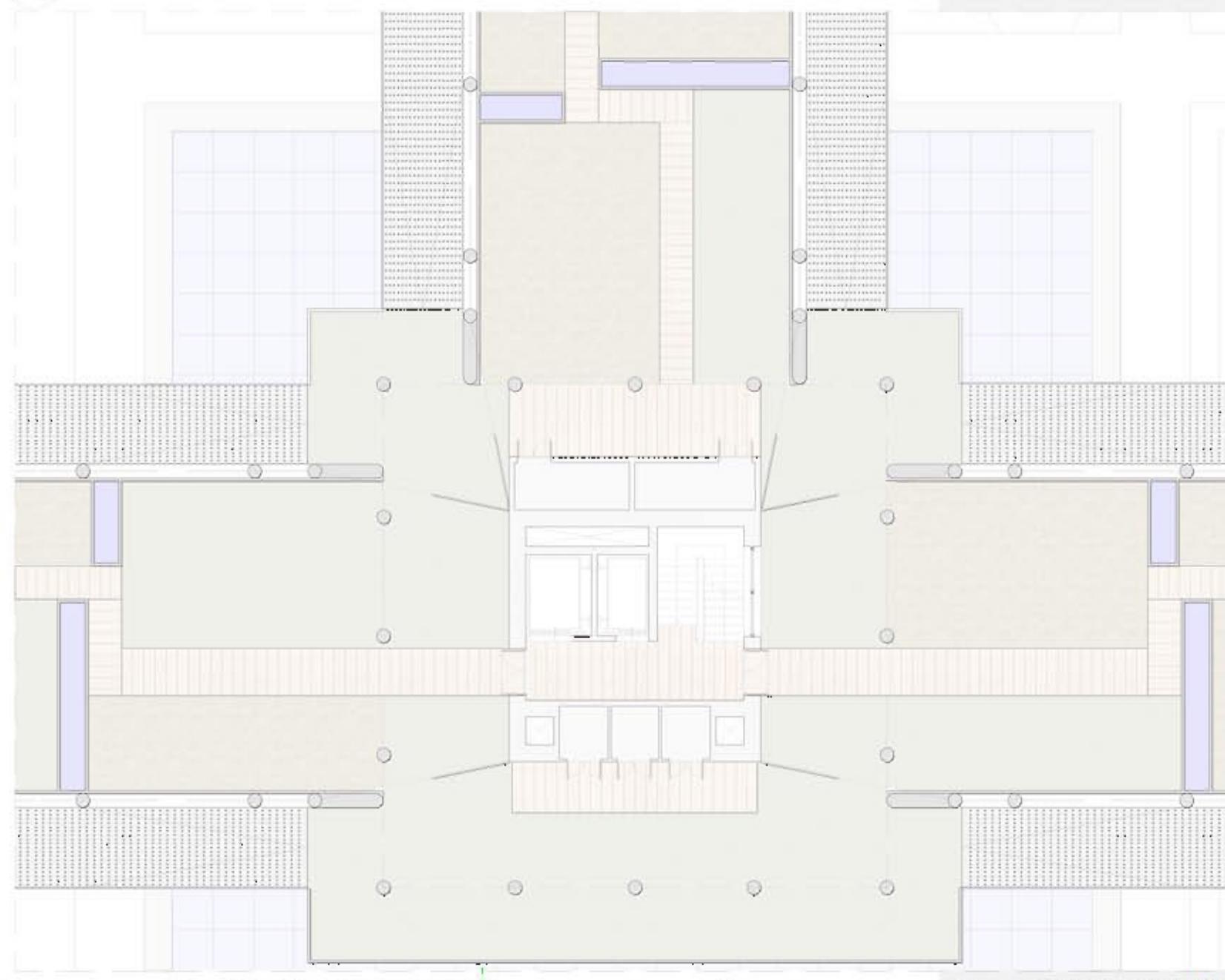
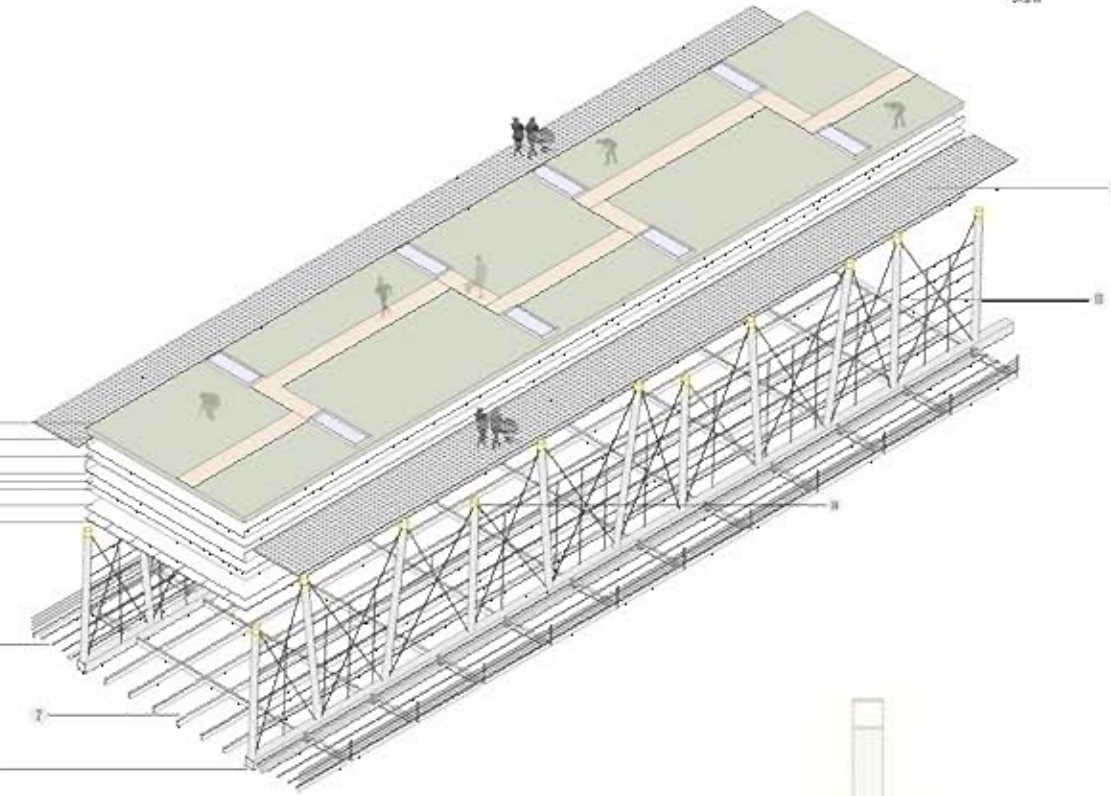

PIANTA LIVELLO -11.06, SCALA 1:100

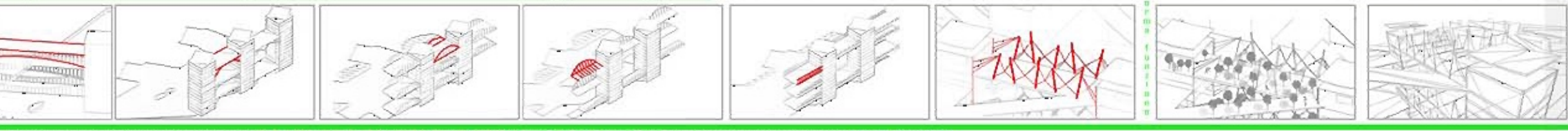

LOFT

london farm tower

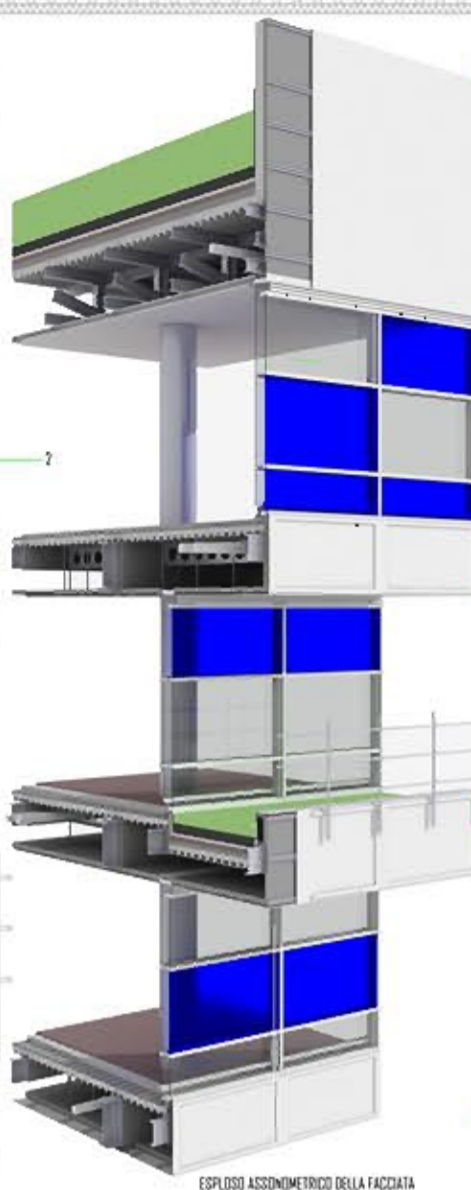
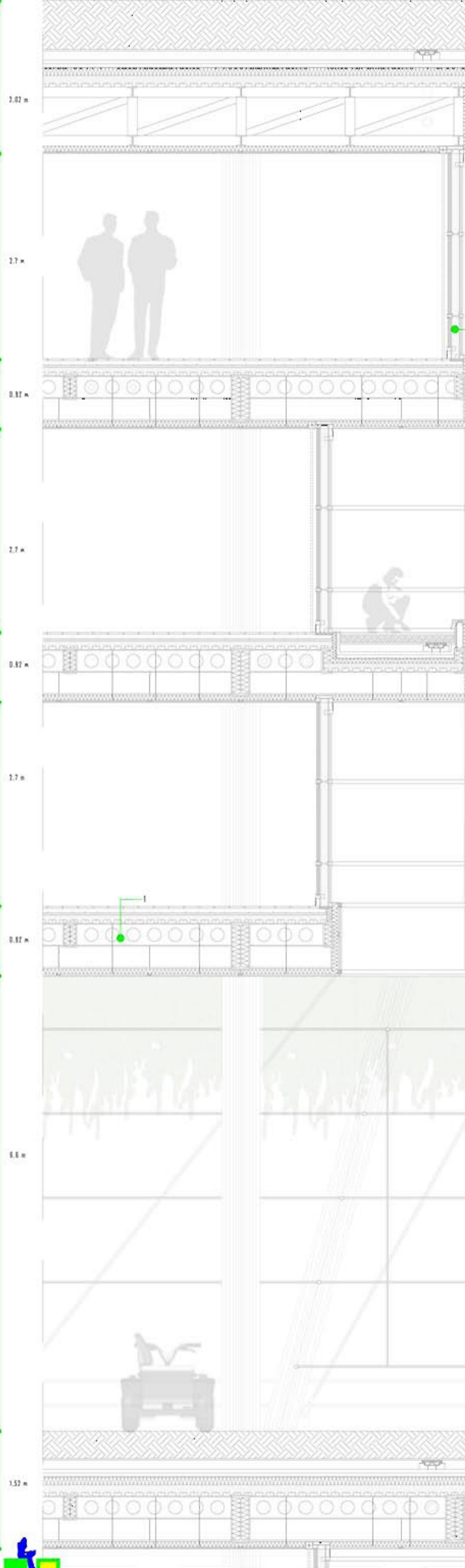

0-PIANO VERDE

Tipi di materiali	Spessori (mm)	Massa (kg/m²)	Resistenza (N/m²)	Spessore equivalente (mm)
1 Isolante termico	15	0,200	1,200	15,000
2 Pannello	10	0,200	1,200	10,000
3 Isolante termico	15	0,200	1,200	15,000
4 Isolante termico	15	0,200	1,200	15,000
5 Isolante termico	15	0,200	1,200	15,000
6 Isolante termico	15	0,200	1,200	15,000
7 Isolante termico	15	0,200	1,200	15,000
8 Isolante termico	15	0,200	1,200	15,000
9 Isolante termico	15	0,200	1,200	15,000
10 Isolante termico	15	0,200	1,200	15,000

Parametri dinamici

Spessore	0,0000 m
Massa superficiale	0,0000 kg/m²
Resistenza	0,0000 W/m²K
Trasmissione	0,0000 W/m²K
Trasmissione periodica	0,0000 W/m²K
Fattore di attenuazione	0,0000
Sfasamento	17h 4'

1-PIANO VERDE

Tipi di materiali	Spessori (mm)	Massa (kg/m²)	Resistenza (N/m²)	Spessore equivalente (mm)
1 Isolante termico	15	0,200	1,200	15,000
2 Pannello	10	0,200	1,200	10,000
3 Isolante termico	15	0,200	1,200	15,000
4 Isolante termico	15	0,200	1,200	15,000
5 Isolante termico	15	0,200	1,200	15,000
6 Isolante termico	15	0,200	1,200	15,000
7 Isolante termico	15	0,200	1,200	15,000
8 Isolante termico	15	0,200	1,200	15,000
9 Isolante termico	15	0,200	1,200	15,000
10 Isolante termico	15	0,200	1,200	15,000

Parametri dinamici

Spessore	0,0000 m
Massa superficiale	0,0000 kg/m²
Resistenza	0,0000 W/m²K
Trasmissione	0,0000 W/m²K
Trasmissione periodica	0,0000 W/m²K
Fattore di attenuazione	0,0000
Sfasamento	7h 24'

2-PIANO INTERNO

Tipi di materiali	Spessori (mm)	Massa (kg/m²)	Resistenza (N/m²)	Spessore equivalente (mm)
1 Isolante termico	15	0,200	1,200	15,000
2 Pannello	10	0,200	1,200	10,000
3 Isolante termico	15	0,200	1,200	15,000
4 Isolante termico	15	0,200	1,200	15,000
5 Isolante termico	15	0,200	1,200	15,000
6 Isolante termico	15	0,200	1,200	15,000
7 Isolante termico	15	0,200	1,200	15,000
8 Isolante termico	15	0,200	1,200	15,000
9 Isolante termico	15	0,200	1,200	15,000
10 Isolante termico	15	0,200	1,200	15,000

Parametri dinamici

Spessore	0,0000 m
Massa superficiale	0,0000 kg/m²
Resistenza	0,0000 W/m²K
Trasmissione	0,0000 W/m²K
Trasmissione periodica	0,0000 W/m²K
Fattore di attenuazione	0,0126
Sfasamento	17h 7'

3-PIANO INTERNO

Tipi di materiali	Spessori (mm)	Massa (kg/m²)	Resistenza (N/m²)	Spessore equivalente (mm)
1 Isolante termico	15	0,200	1,200	15,000
2 Pannello	10	0,200	1,200	10,000
3 Isolante termico	15	0,200	1,200	15,000
4 Isolante termico	15	0,200	1,200	15,000
5 Isolante termico	15	0,200	1,200	15,000
6 Isolante termico	15	0,200	1,200	15,000
7 Isolante termico	15	0,200	1,200	15,000
8 Isolante termico	15	0,200	1,200	15,000
9 Isolante termico	15	0,200	1,200	15,000
10 Isolante termico	15	0,200	1,200	15,000

Parametri dinamici

Spessore	0,0000 m
Massa superficiale	0,0000 kg/m²
Resistenza	0,0000 W/m²K
Trasmissione	0,0000 W/m²K
Trasmissione periodica	0,0000 W/m²K
Fattore di attenuazione	0,0126
Sfasamento	17h 7'

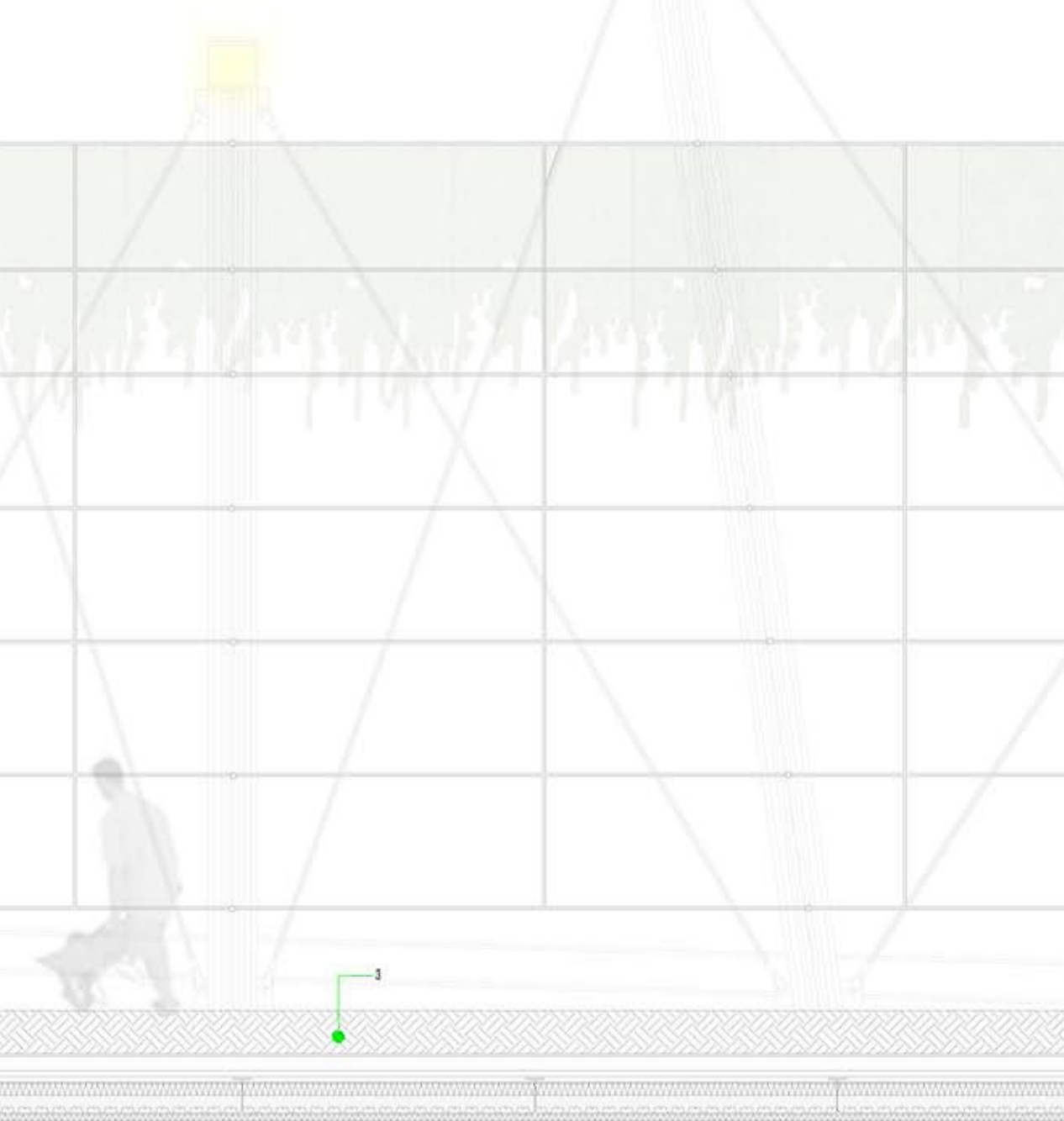

- LEGENDA**
- 1 SOLAIO ANTISPANDO:**
 - pavimento in listelli di legno, sp. 25 mm
 - costr. in c/c, sp. 60 mm
 - pannelli radianti a pavimento, 4.10 mm
 - isolante in polietilene, sp. 20 mm
 - trave sp. 600
 - isolante in lana di roccia, sp. 70 mm
 - massa termica DUPONT ENERGAIN, sp. 5.6 mm
 - controsolotto in cartongesso, sp. 15 mm
 - 2 PARETE TRASPARENTE:**
 - vetro clear 16, sp. 15.62 mm
 - aria, 120 mm
 - vetro low-e 6-20-6 mm
 - isolizi d'aria in alluminio forato per la ventilazione
 - 3/4 PIANI YERDI:**
 - substrato culturale, sp. 650/400 mm
 - strato filtrante polistirene, sp. 2 mm
 - ghiaia, sp. 100 mm
 - soletta in c/c, sp. 40 mm
 - sabbia, sp. 40 mm
 - film in polietilene espanso, sp. 4 mm
 - isolante in lana di roccia, sp. 70 mm
 - soletta c/c, sp. 60 mm
 - struttura reticolare, sp. 1000 mm
 - isolante in lana di roccia, sp. 70 mm
 - 5 MASSA TERMICA:**
 - massa termica DUPONT ENERGAIN, sp. 5.6 mm
 - controsolotto in cartongesso, sp. 15 mm

LOFT

london farm tower

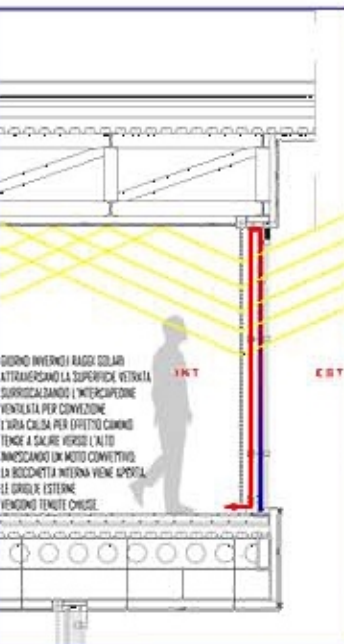
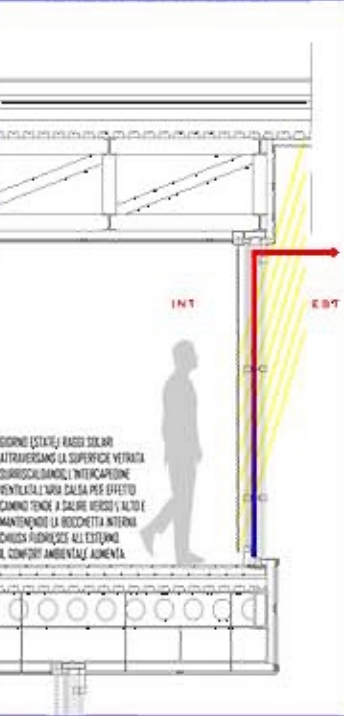

MODELLI PER LO STUDIO DELL'INVOLUCRO_PARETI SUD-EST E OVEST

